

**OPERATOR'S MANUAL**

**RK74**  
Power Shuttle

Rural King Supply  
4216 Dewitt Ave.  
Mattoon IL 61938



**Rural King**

**RK** TRACTORS  
**OPERATOR'S MANUAL**

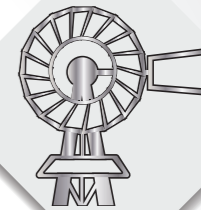

**RK74**  
**Power Shuttle**

## FOREWORD

Thank you for purchasing our tractor. We are confident it will give you many years of reliable Service.

The introduction in this manual sets out the correct manner of operating, maintaining and checking the tractor to ensure long-term durability.

Please ensure correct operation of the tractor as incorrect operation can cause substantial mechanical damage as well as cause accidents with the associated injuries.

Please note that in some cases differences can exist between this manual and your tractor due to the manufacturer's policy of constant product improvement.

In the event that you encounter a problem not covered by this manual please contact your nearest dealer who will assist you in resolving your problem.







**WARNING**

### **CALIFORNIA Proposition 65 Warning**











**The Engine Exhaust from this product contains chemicals known to the state of California to cause cancer, birth defects or other reproductive harm.**

## WARNING SIGNS IN THIS MANUAL

The following warning signs in this manual draw additional attention to items of importance for the safe and correct operation of the tractor.

SIGN	MEANING OF THE SIGN
 <b>DANGER</b>	This indicates that a condition may result in harm, serious injury or death to you or other persons if the warning is not heeded. Follow the advice provided with the warning.
 <b>WARNING</b>	Hazard or unsafe practice that can lead to severe injury or death.
 <b>CAUTION</b>	Hazard or unsafe practice that can lead in injury or death.
 <b>IMPORTANT</b>	Instructions for the correct operation of the machine which, if followed, will ensure that it performs at it's best.

All information, illustrations and specifications in this manual are based on latest information available at the time of publication. The right is reserved to make changes at any time without notice.

<b>GENERAL INFORMATION</b>		<b>1</b>
<b>SAFETY PRECAUTIONS</b>		<b>2</b>
<b>DESCRIPTION OF TRACTOR CONTROLS</b>		<b>3</b>
<b>OPERATION</b>		<b>4</b>
<b>MAINTENANCE</b>		<b>5</b>
<b>CABIN SYSTEM</b>		<b>6</b>
<b>SPECIFICATION</b>		<b>7</b>
<b>TROUBLESHOOTING</b>		<b>8</b>
<b>APPENDIX</b>		<b>9</b>
<b>INDEX</b>		<b>10</b>
<b>WARRANTY</b>		<b>11</b>

## TABLE OF CONTENTS



### GENERAL INFORMATION

1

1. EXTERIOR VIEW ..... 1-2
2. TRACTOR IDENTIFICATION..... 1-5
3. ABOUT THIS MANUAL ..... 1-6
4. INTRODUCTION & DESCRIPTION ..... 1-7
5. OWNER ASSISTANCE .... 1-9
6. ROPS (ROLL OVER PROTECTIVE STRUCTURES) .. 1-10



### SAFETY PRECAUTIONS

2

1. SAFETY INSTRUCTIONS .....2-2
2. DO'S AND DON'T'S .....2-20
3. SAFETY SIGNS .....2-22
4. UNIVERSAL SYMBOLS ..2-27



### DESCRIPTION OF TRACTOR CONTROLS

3

1. INSTRUMENT AND SWITCHES .....3-2

2. OPERATION THE CONTROLS .....3-10
3. OPERATING THE 3 POINT LINKAGE (TPL) 3-22



### OPERATION

4

1. STARTING THE ENGINE ..4-2
2. STOPPING THE ENGINE ..4-3
3. DRIVING THE TRACTOR...4-3
4. CONNECTING AND DISCONNECTING IMPLEMENT .....4-10



### MAINTENANCE

5

1. CHECKS AND SERVICE ..5-2
2. MAINTENANCE AND ADJUSTMENT SCHEDULE .....5-7
3. TIRE SIZE AND INFLATION PRESSURE ..5-9
4. FILLING DIAGRAM & CAPACITY TABLE .....5-10

5. LUBRICANTS..... 5-11
6. OPENING METHOD OF EACH COVER .....5-12
7. BLEEDING THE FUEL SYSTEM .....5-13
8. CHANGING THE OILS IN THE TRACTOR .....5-14
9. CLEANING AND CHANGING FILTERS ...5-17
10. CHANGING THE COOLANT .....5-20
11. GREASING THE TRACTOR.....5-22
12. GAP ADJUSTMENT .....5-23
13. BATTERY MAINTENANCE.....5-25
14. OTHER MAINTENANCE.....5-27
15. STORAGE .....5-30
16. FUEL SAVING TIPS .....5-32

 **CABIN SYSTEM** **6**

- 1. MAJOR FEATURES .....6-2
- 2. INSTRUMENT AND RELATED PARTS .....6-3
- 3. HOW TO CONTROLS CABIN .....6-5

 **SPECIFICATION** **7**

- 1. SPECIFICATIONS .....7-2

 **TROUBLESHOOTING** **8**

- 1. ENGINE TROUBLESHOOTING ....8-2
- 2. CLUTCH, BRAKE AND HYDRAULIC SYSTEM TROUBLESHOOTING ....8-6
- 3. STEERING WHEEL AND ELECTRIC INSTRUMENTS TROUBLESHOOTING ....8-7
- 4. TOWING THE TRACTOR...8-8

 **APPENDIX** **9**

- 1. POSITION OF THE FUSE.9-2
- 2. WIRING DIAGRAM OF THE ELECTRIC INSTRUMENT.....9-2
- 3. TRACTOR HISTORY CARD .....9-3
- 4. SERVICE RECORD .....9-4
- 5. DAILY OPERATION LOG ..9-5
- 6. PART REPLACEMENT RECORD .....9-6
- 7. ENGINE OIL MANUFACTURER .....9-7
- 8. COOLANT MANUFACTURER .....9-10

 **INDEX** **10**

- 1. INDEX.....10-2

 **WARRANTY** **11**

- 1. ENGINE WARRANTIES.. 11-2
- 2. EMISSION SYSTEM WARRANTY..... 11-5
- 3. RK WARRANTY ..... 11-13





## GENERAL INFORMATION

<b>1. EXTERIOR VIEW .....</b>	<b>1-2</b>
<b>2. TRACTOR IDENTIFICATION .....</b>	<b>1-5</b>
<b>3. ABOUT THIS MANUAL .....</b>	<b>1-6</b>
<b>4. INTRODUCTION &amp; DESCRIPTION .....</b>	<b>1-7</b>
<b>5. OWNER ASSISTANCE .....</b>	<b>1-9</b>
<b>6. ROPS (ROLL OVER PROTECTIVE STRUCTURES) ....</b>	<b>1-10</b>





1. EXTERIOR VIEW

※ Figures in this manual are based on the model RK74PSC.

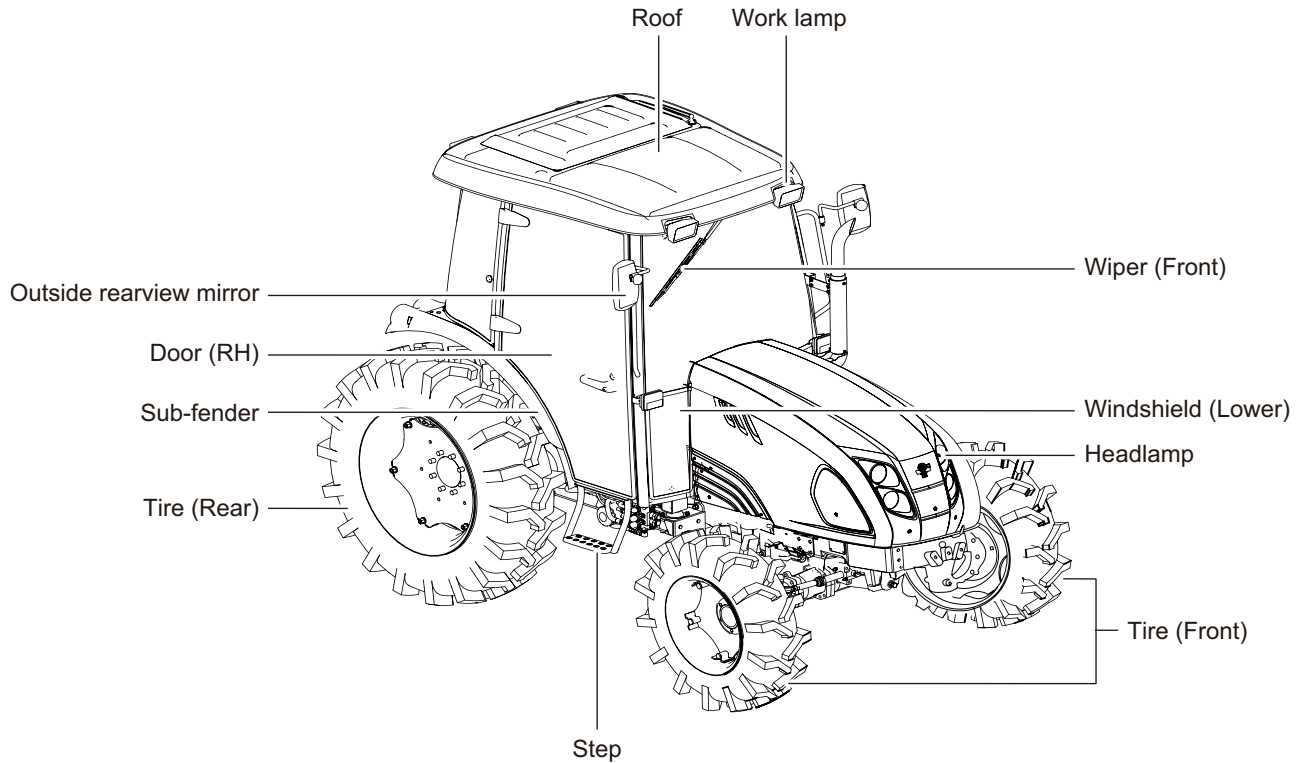

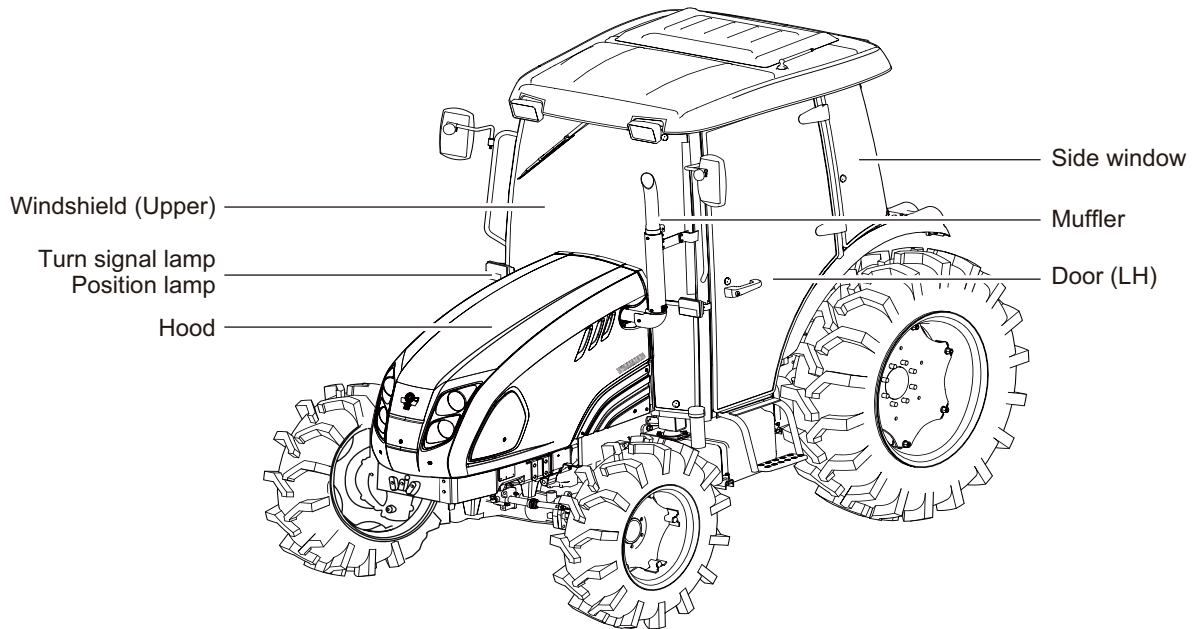



## GENERAL INFORMATION

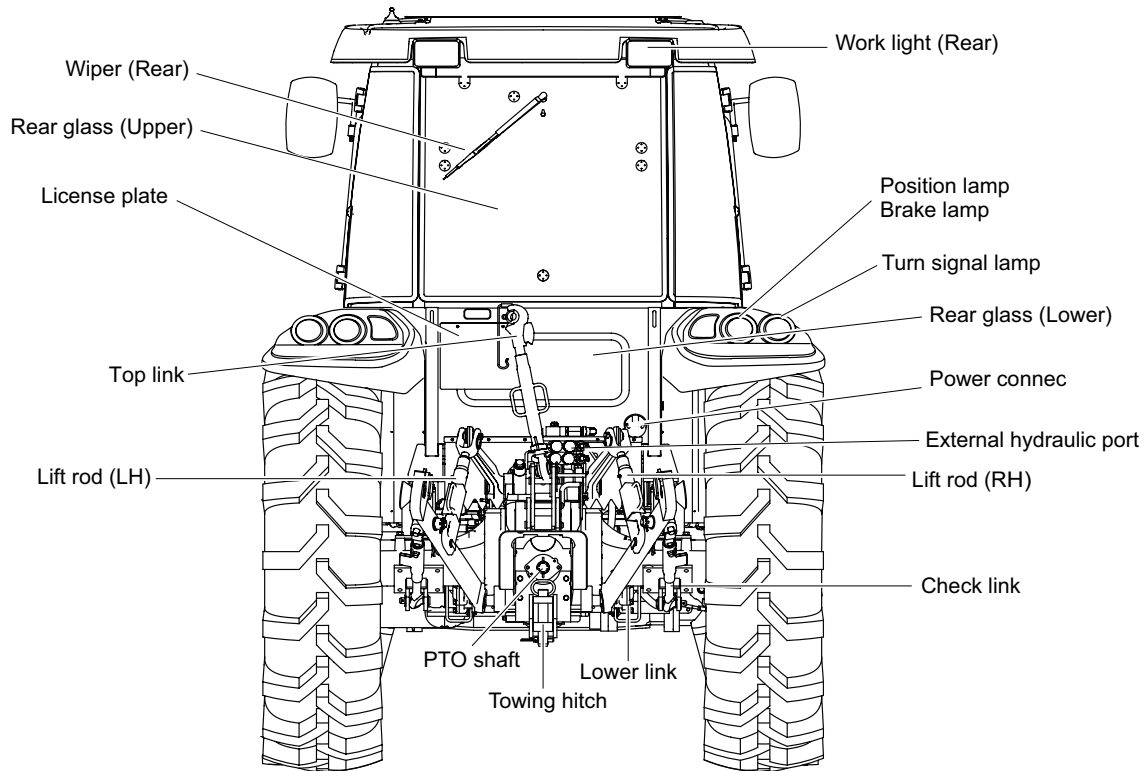



## 2. TRACTOR IDENTIFICATION

The engine number is stamped on the left hand side of the engine block.  
The chassis number is shown on the left hand side of the tractor as shown in the drawing.

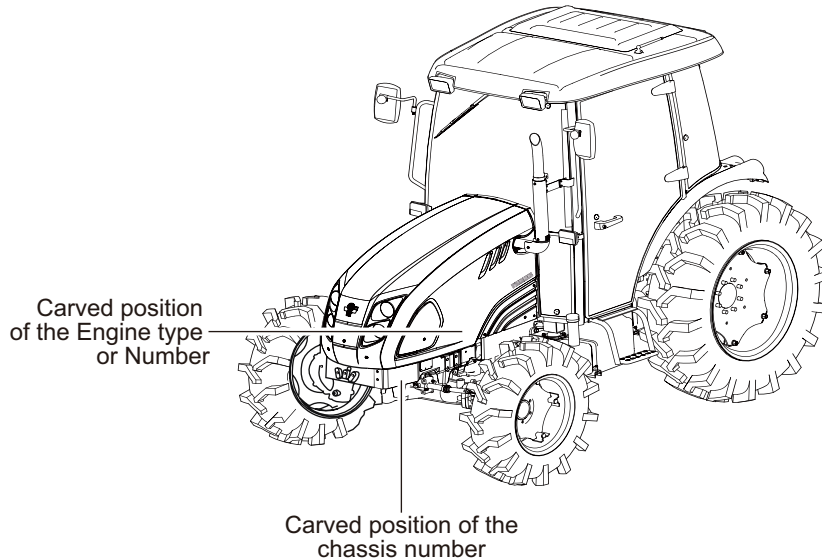

R740103B

### ► WARRANTY OF THE PRODUCT

The manufacturer warrants this product and full details of the warranty are provided on a separate warranty schedule.

### ► SERVICE

Service is available from any **Rural King** dealer in the country.

### ► PARTS

To obtain spare parts please contact your nearest dealer and give him the details listed below.

- Tractor model
- Tractor serial number
- Tractor engine number
- Part number and description
- Quantity required



### 3. ABOUT THIS MANUAL

This manual has been prepared to assist you in following/adopting the correct procedure for running-in operation and maintenance of your new **Rural King Supply, Inc** (Here in after refer to **Rural King**) tractor.

Your tractor has been designed and built to give maximum performance, with good fuel economy and ease of operation under a wide variety of operating conditions. Prior to delivery, The tractor was carefully inspected, both at the factory and by your **Rural King** Dealer/Distributor, to ensure that it reaches you in optimum conditions .To maintain this condition and ensure trouble free performance. it is important that the routine services, as specified in this manual, are carried out at the recommended intervals.

Read this Manual carefully and keep it in a convenient place for future reference. If at any time you require advice concerning your tractor, do not hesitate to contact your Authorized **Rural King** dealer/Distributor. He has trained personnel, genuine parts and necessary equipments to undertake all your service requirements.

Manufacturer's policy is one of continuous improvement, and the right to change prices, specifications or equipments at any time without notice is reserved.

All data given in this book is subject to production variations. Dimensions & weight are approximate only and the illustrations do not necessarily show tractors in standard condition. For exact information about any particular tractor, please consult your **Rural King** dealer/Distributor.



## 4. INTRODUCTION & DESCRIPTION

### ► TRACTOR AN INTRODUCTION

The word, 'tractor' has been derived from 'traction' which means pulling.

A tractor is required to pull or haul an equipment, implement or trolley which are coupled to the tractor body through suitable linkage. A tractor can also be used as a prime mover as it has a power outlet source which is also called Power Take or PTO shaft.

In this book the operating, maintenance and storage instructions for all models of **Rural King** Diesel tractors has been compiled. This material has been prepared in detail to help you in the better understanding of maintenance and efficient operation of the machine.

If you need any information not given in this manual, or require the services of a trained mechanic, please get in touch with the **Rural King** Dealer/Distributor in your locali-

ty. Dealer/Distributors are kept informed of the latest methods of servicing tractors. They stock genuine spare parts and are backed by the Company's full support.

Through this manual. The use of the terms LEFT, RIGHT, FRONT and REAR must be understood, to avoid any confusion when following the introductions. The LEFT and RIGHT means left and right sides of the tractor when facing forward in the driver's seat, Reference to the FRONT indicates the radiator end of the tractor, while the REAR, indicates the drawbar end.

When spare parts are required, always specify the tractor and engine serial number when ordering these parts. (See illustration A). This will facilitate faster delivery and help ensure that the correct parts for your particular tractor is received. The tractor serial number is punched on a plate attached to the left hand side

of the engine body (Illust. A), For easy reference, we suggest you to write the number in the space provided in the owner's personal data.

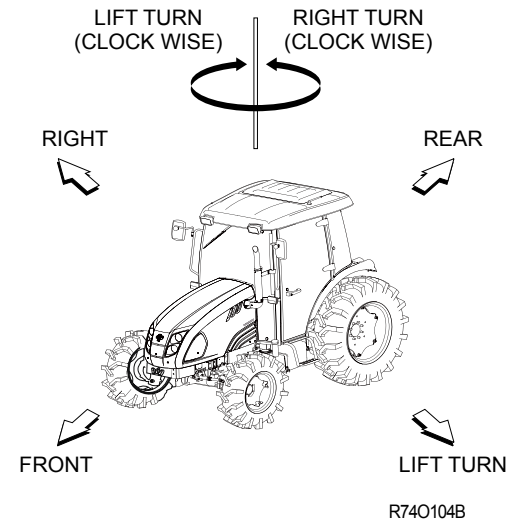



### ► DESCRIPTION

#### GENERAL CONSTRUCTION

The transmission case, Clutch, Clutch housing, Engine and Front Axle Support are bolted together to form a rigid unit.

#### FRONT AXLE & WHEELS

The 4WD front axle is a center-pivot, reverse Eliot type. The front wheel drive mechanism is incorporated as a part of the axle.

The front wheel drive power is taken off the rear transmission and transmitted to the differential in the front axle where the power is divided into right and left and to the respective final cases.

In the final cases, the transmitted revolution is reduced by the level gears to drive the front wheel. The 4WD mechanism with level gears provides wider steering and greater durability.

#### ENGINE

The tractors are fitted with fuel efficient Turbo charged engines with 4 cylinders of RK74PSC designed by DEUTZ Engines Company.

#### CLUTCH AND TRANSMISSION

A single plate dry clutch (11.81" diameter) is used on these tractors. Tractor with IPTO (Independent Power Take Off) are fitted with hydraulic Clutch Assy. The transmission Gear box has Twenty four forward & Twenty four reverse speeds of MAJORHS65 with high-low selector lever, Presently, **Rural King** tractors are fitted with partial synchro mesh type gears.

#### BRAKES

**Rural King** tractors are provided with independent disc brakes operated by two road travel. Hand brake lever is fitted for parking.

#### REAR AXLE & WHEELS

This is mounted on ball bearings and is enclosed in removable housing which are bolted to the transmission case. The rim & Disc fitted with Rear tires are bolted to the outer flange of Rear Axle.

#### HYDRAULIC SYSTEM & LINKAGES

**Rural King** tractors are fitted with Live (i.e. system is in operation even when clutch is disengaged.) independent, very touch of hydraulic System. Three point Linkages can be used for category 2 type of implements.

#### STEERING

It consists of Hydrostatic Power steering system, which has a hydraulic cylinder and tandem type hydraulic pump.



## 5. OWNER ASSISTANCE

### ELECTRICAL SYSTEM

A 12 Volt Lead Acid Propylene Battery is used to activate the Engine through the Starter Motor and the Electrical system comprising Horn, Head Lamp, Side indicator Lamps, Plough Lamp, Brake Light, Gauge lamp, Hazard Lamp, Generator or Alternator, Fuse box also from part of the Electrical system.

#### WARNING

- When operating the tractor at High speed, Do not attempt to make sharp turns by using the brakes. This may result in overturning of the tractor causing serious injury or DEATH.

We at **Rural King company** and your **Rural King Dealer/Distributor** wants you to be completely satisfied with your investment. Normally any problems with your equipment will be handled by your Dealer/Distributor's Service Departments, however, misunderstanding can occur. If you feel that your problem has not been handled to your satisfaction, we suggest the following.

Contact the owner or General Manager of the Dealership, explain the problem, and request assistance. When additional assistance is needed, Your Dealer/Distributor has direct access to your office. If you cannot obtain satisfaction by doing this, contact the **Rural King Supply, Inc** Office and provide them with;

- Your name, address and telephone number
- Model and tractor serial number
- Dealer/Distributor Name & Address
- Machine purchase date and Hours used
- Nature of problem

Before contacting **Rural King Supply, Inc** office, be aware that your problem will likely to be resolved in the Dealership using the Dealer's/Distributor's facilities, equipment and personnel. So it is important that your initial contact be with the Dealer/Distributor.





### 6. ROPS (ROLL OVER PROTECTIVE STRUCTURES)

#### ► ROLL OVER PROTECTIVE STRUCTURES (ROPS)

**Rural King** tractors are equipped with a frame for the protection of operators.

In the case of cab tractors the frame is incorporated in the cab structure.

The objective of the frame or cab structure is to protect the operator in the event of a roll over

and they are designed to support the entire weight of the tractor in that event.

Each **Rural King** ROPS frame or cab structure is designed and has been tested to meet industry and or government standards.

Included in these tests were all mounting bases and bolts or other fasteners.

#### DANGER

- For ROPS frames to be effective and protect the operator, the seat belt provided must be worn in order to keep operators within the ROPS protected area in the event of a roll over. Failure to use the seat belt can still cause serious injury or death.

On some models the ROPS frame has a fold down feature, which can be used to enter low buildings etc.

Take care when lowering the upper section of the ROPS frame and take extreme care while driving the tractor with the ROPS frame lowered.

Do not wear the seat belt with the ROPS lowered and please remember that the fold down facility is for special circumstances only and must not be lowered for general use.

#### ► USE OF THE TRACTOR WITH THE ROPS LOWERED CAN CAUSE FATAL INJURIES

As the ROPS frame or cab together with the seat belt was designed to meet certain standards, they must be maintained in good order and condition. To achieve this objective, both the structure and the seat belt should be inspected on a regular basis. (Every time the tractor is serviced)

In the event that the seat belt is damaged or frayed, it should be replaced and in the event that the ROPS frame or any part of the mounting structure is damaged or cracked, the faulty component must be replaced with a new unit. Such a unit must meet all of the test criteria of the original unit. Fitment of an inferior item or items affects the certification of the entire ROPS structure and the effectiveness of the structure in the event of an accident. Drilling or welding of the ROPS structure is forbidden.

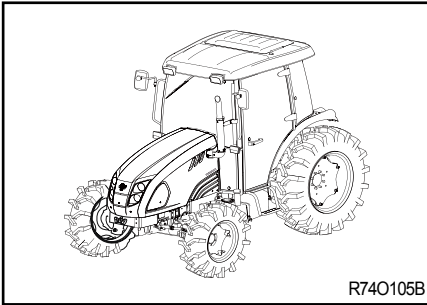

### ► DAMAGE OF THE ROPS

If the tractor has rolled over or the ROPS has damaged (such as striking an overhead object during transport), It must be replaced to provide the original protection. After an accident, check for damages to the 1.ROPS. 2.Seat. 3.seat belt & seat mountings. Before you operate a tractor, replace all damaged parts.

#### ⚠ WARNING

- Do not weld, drill or straighten the ROPS.

#### ⚠ WARNING

- Never attach chains, ropes to the ROPS for pulling purposes; this will cause the tractor to tip backwards. Always pull from the tractor drawbar. Be careful when driving through door opening or under low overhead objects. Make sure there is sufficient overhead clearance for the ROPS fatal injuries.

#### ⚠ WARNING

- If the ROPS is removed or replaced, make certain that the proper hardware is used to replace the ROPS and the recommended torque values are applied to the attaching bolts.

#### ⚠ WARNING

- Always wear your seat belt if the tractor is equipped with ROPS.

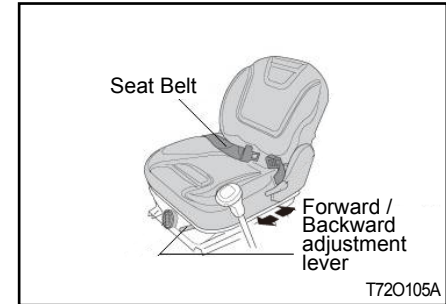

### ► SEAT SLIDING

Before operating a tractor it is important to adjust the seat to the most comfortable position & check whether it is properly locked in its position.

#### NOTE

- Do not use solvents to clean the seat. Use warm water with a little detergent added.



### CAUTION

- Do not put a hand between the seat and the slides when adjusting the seat position. You can get injured unexpectedly.

To select Seat position, move Adjusting lever and slide Seat closer to or away from Dash panel and controls.

### DANGER

- Check whether the seat properly locked in its position before driving the tractor.

### DANGER

- Always use the seat belt when the ROPS is installed. Do not use the seat belt if a foldable ROPS is down or there is no ROPS. Check the seat belt regularly and replace if frayed or damaged.

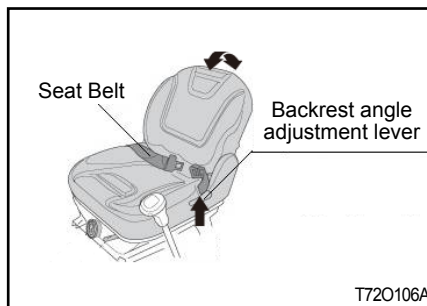

### ► SEAT BACK RECLINING

To change the seatback angle, raise the lever on the left of the seat.

Then, adjust the seatback angle with the lever pulled. Release the lever after adjustment. Make sure that the lever is returned and the seat is firmly fixed after adjustment.

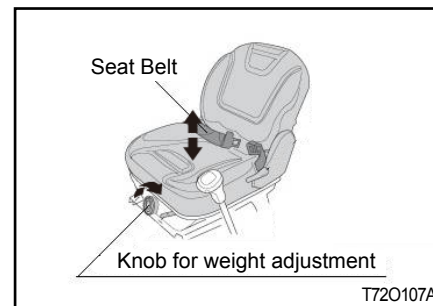

### ► CUSHION STRENGTH ADJUSTMENT

The seat cushion can be adjusted according to the weight of the driver.

Turning the cushion adjustment lever counterclockwise to the 50kg position makes the cushion lighter, and turning the lever clockwise to the 130kg position makes the cushion heavier.

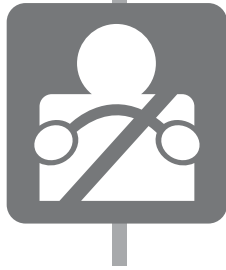

## **SAFETY PRECAUTIONS**

<b>1. SAFETY INSTRUCTIONS .....</b>	<b>2-2</b>
<b>2. DO'S AND DON'T'S .....</b>	<b>2-20</b>
<b>3. SAFETY SIGNS .....</b>	<b>2-22</b>
<b>4. UNIVERSAL SYMBOLS .....</b>	<b>2-27</b>



### 1. SAFETY INSTRUCTIONS



#### ► **RECOGNIZE SAFETY INFORMATION**

This symbol means ATTENTION! YOUR SAFETY IS INVOLVED. The message that follows the symbol contains important information about safety. Carefully read the message.



#### ► **SIGNAL WORDS**

A signal word "DANGER, WARNING OR CAUTION" is used with safety alert symbol. DANGER identifies the most serious hazards. Safety signs with signal Word "DANGER OR WARNING" are typically near specific hazards. General precautions are listed on CAUTION safety signs.

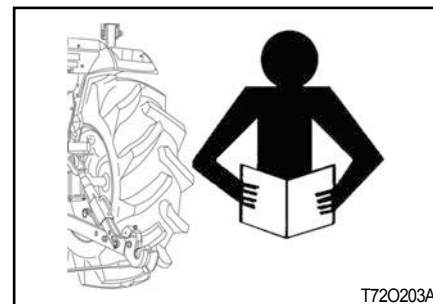

#### ► **READ SAFETY INSTRUCTION**

Carefully read all safety instructions given in this manual for your safety. Tempering with any of the safety devices can cause serious injuries or death. Keep all safety signs in good condition. Replace missing or damaged safety signs.

Keep your tractor in proper condition and do not allow any unauthorized modifications to be carried out on the tractor, which may impair the function/safety and affect tractor life.

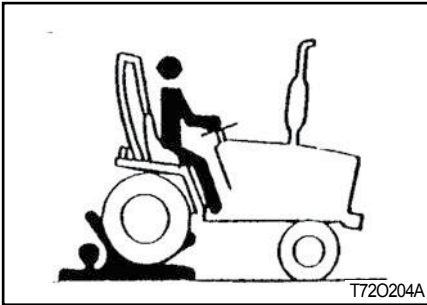

#### ► PROTECTION CHILDREN

Keep children and others away from the tractor while operating.

#### BEFORE YOU REVERSE:

- Look behind tractor for children.
- Do not let children to ride on tractor or any implement.

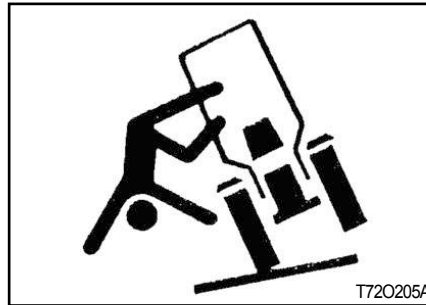

#### ► USE OF ROPS AND SEAT BELT

The Roll Over Protective Structure (ROPS) has been certified to industry and/or government standards. Any damage or alternation to the ROPS, mounting hardware, or seat belt voids the certification and will reduce or eliminate protection for the operator in the event of a roll-over. The ROPS, mounting hardware, and seat belt should be checked after the first 100 hours of tractor and every 500 hours thereafter for any evidence of damage,

wear or cracks. In the event of damage or alteration, the ROPS must be replaced prior to further operation of the tractor.

The seat belt must be worn during machine operation when the machine is equipped with a certified ROPS.

Failure to do so will reduce or eliminate protection for the operator in the event of a roll over.



## SAFETY PRECAUTIONS

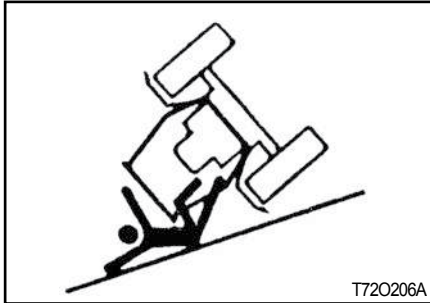

### ► PRECAUTION TO AVOID TIPPING

Do not drive where the tractor could slip or tip.

Stay alert for holes and rocks in the terrain, and other hidden hazards.

Slow down before you make a sharp turn.

Driving forward out of a ditch or mired condition could cause tractor to tip over backward. Back out of these situations if possible.

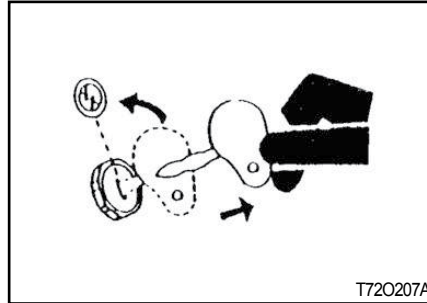

### ► PARK TRACTOR SAFELY

Before working on the tractor;

Lower all equipment to the ground.

Stop the engine and remove the key.



### ► KEEP RIDERS OFF TRACTOR

Do not allow riders on the tractor.

Riders on tractor are subject to injury such as being stuck by foreign objects and being thrown off of the tractor.

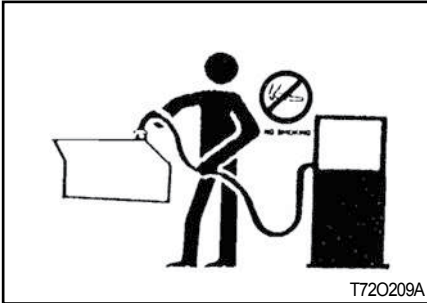

► **HANDLE FUEL SAFELY AVOID FIRES**

Handle fuel with care; it is highly flammable. Do not refuel the tractor while smoking or near open flame or sparks.

Always stop engine before refueling tractors.

Always keep your tractor clean of accumulated grease, and debris. Always clean up spilled fuel.



► **STAY CLEAR OF ROTATING SHAFTS**

Entanglement in rotating shaft can cause serious injury or death.

Keep PTO shield in place at all times.

Wear close fitting clothing. Stop the engine and be sure PTO drive is stopped before making adjustments, connections, or cleaning out PTO driven equipment.

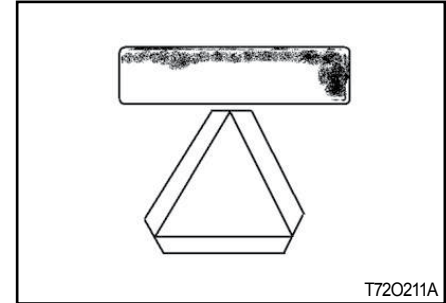

► **ALWAYS USE SAFETY LIGHTS AND DEVICES**

Use of hazard warning lights and turn signals are recommended when towing equipment on public roads unless prohibited by state or local regulations.

Use slow moving vehicle (SMV) sign when driving on public road during both day & night time, unless prohibited by law.





## SAFETY PRECAUTIONS



### ► PRACTICE SAFE MAINTENANCE

Understand service procedure before doing work.

Keep the surrounding area of the tractor clean and dry.

Do not attempt to service tractor when it is in motion.

Keep body and clothing away from rotating shafts.

Always lower equipment to the ground. Stop the engine.

Remove the key. Allow tractor to cool before any work repair is caused on it.

Securely support any tractor elements that must be raised for service work.

Keep all parts in good condition and properly installed.

Replace worn or broken parts. Replace damage/missing decals.

Remove any buildup of grease or oil from the tractor.

Disconnect battery ground cable(-) before making adjustments on electrical systems or welding on tractor.



### ► AVOID HIGH-PRESSURE FLUIDS

Escaping fluid under pressure can penetrate the skin causing serious injury. Keep hands and body away from pinholes and nozzles, which eject fluids under high pressure. If any fluid is injected into the skin. Consult your doctor immediately.



### ► PREVENT BATTERY EXPLOSIONS

Keep sparks, lighted matches, and open flame away from the top of battery. Battery gas can explode.

Never check battery charge by placing a metal object across the poles.

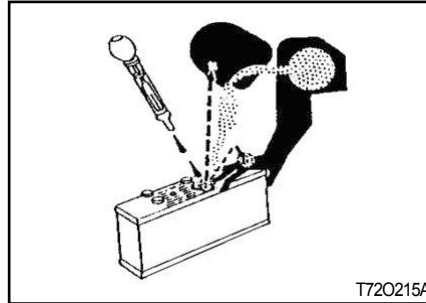

### ► PREVENT ACID BURNS

Sulfuric acid in battery electrolyte is poisonous. It is strong enough to burn skin, cause holes in clothing and cause blindness if found entry into eyes.

For adequate safety always;

1. Fill batteries in a well-ventilated area.
2. Wear eye protection and acid proof hand gloves.
3. Avoid breathing direct fumes when electrolyte is added.

4. Do not add water to electrolyte as it may splash off causing severe burns.

If you spill acid on yourself;

1. Flush your skin with water.
2. Flush your eyes with water for 10-15 minutes.

Get medical attention immediately.



## SAFETY PRECAUTIONS

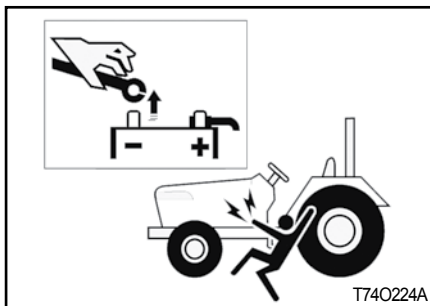

### ► BATTERY DISCONNECT

1. When working with your tractors electrical components you must first disconnect the battery cables.
2. To ensure that there are no accidents from sparks you must first disconnect the negative battery cable.

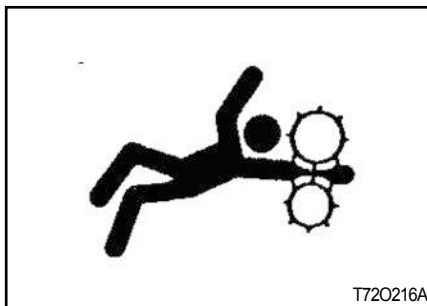

### ► SERVICE TRACTOR SAFELY

Do not wear a necktie, scarf or loose clothing when you work near moving parts. If these items were to get caught, severe injury could result.

Remove rings and other jewelry to prevent electrical shorts and entanglement in moving parts.

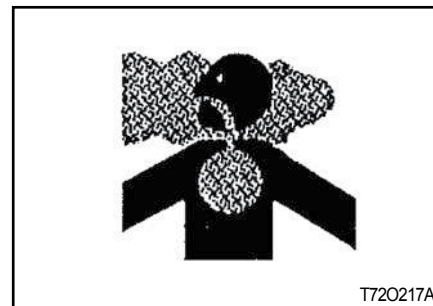

### ► WORK IN VENTILATED AREA

Do not start the tractor in an enclosed building unless the doors & windows are open for proper ventilation, as tractor fumes can cause sickness or death. If it is necessary to run an engine in an enclosed area remove the exhaust fumes by connecting exhaust pipe extension.



### ► TRACTOR RUNAWAY

1. The tractor can start even if the transmission is engaged position causing tractor to runaway and serious injury to the people standing nearby the tractor.
2. For additional safety keep the pull to stop knob (Fuel shut off control) in fully pulled out position.

Transmission in neutral position, Foot brake engaged and PTO lever in disengaged position while attending to Safety Starter Switch or any other work on tractor.

### ► SAFETY STARTER SWITCH

1. Clutch operated safety switch is provided on all tractors which allow the starting system to become operational only when the Clutch pedal is fully pressed.
2. Do not By-pass this safety starter switch or work on it. Only Authorized Dealers are recommended to work on safety starter switch.
3. On some models Safety Starter switch is provided on transmission High-low shifter lever and in PTO shifter lever. The tractor can be started only if High-low shifter lever is in neutral position.

#### ▲ CAUTION

- Safety Starter Switch is to be replaced after every 2,000 hours/4 years, whichever is earlier.

### ► EMERGENCY EXITS

If exit from the cab side doors is blocked (following an accident or vehicle overturn) the alternative safety exits are indicated by decals.

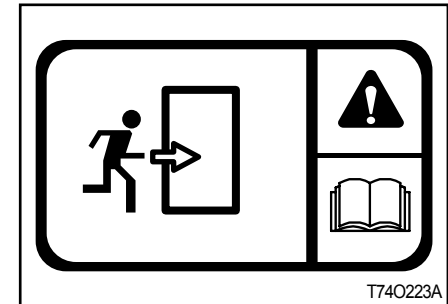

The possible safety exits are:

- Rear window hatch (All tractors)
- Front window (for versions with openable front window).



## SAFETY PRECAUTIONS

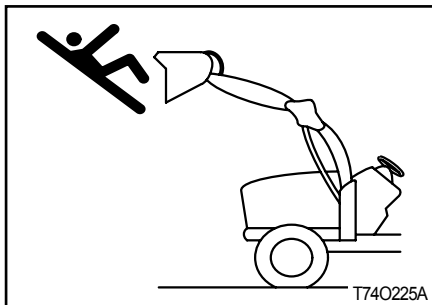

### ► SAFETY PRECAUTIONS WHEN USING THE LOADER

Never let anyone get in the loader and use the loader as a workbench. Otherwise, it may lead to a fatal injury or even death.

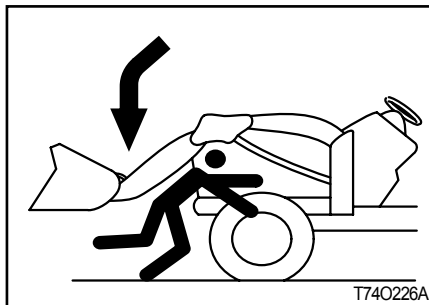

Do not stand under the lifted loader or get close to it. Also, lower the loader arm onto the ground before leaving the tractor. Otherwise, it may lead to a fatal injury or even death.

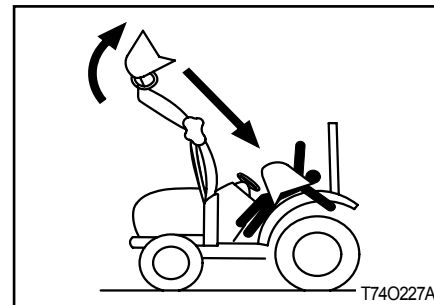

When attaching or detaching the loader, fix all parts which are connected to the bucket and boom. The bucket or boom can be accidentally dropped down, leading to an injury or even death.

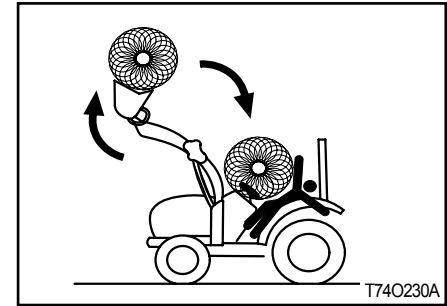
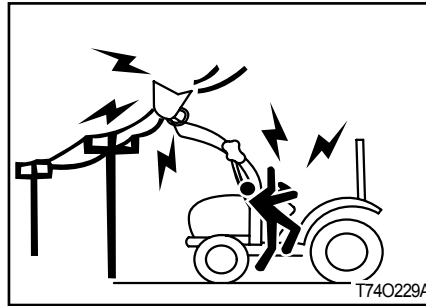
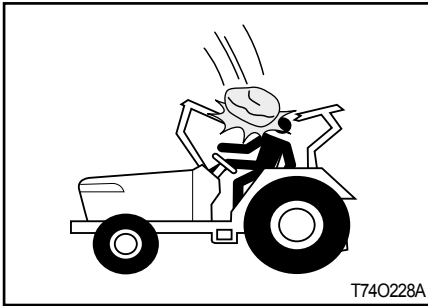
**IMPORTANT**

- ROPS (Roll Over Protective Structure), sun canopy or cabin are not a FOPS (Falling Object Protective Structure).

It never can protect the riders against falling objects.

Avoid driving the vehicle into a dangerous area such as falling rocks zone.

Do not allow loader arms or attachment to contact electrical power lines. Electrocutation will cause serious injury or death.

Never carry a big object with the loader unless a proper implement is attached. Keep a carried object low during driving. Otherwise, it may lead to an injury or even death.

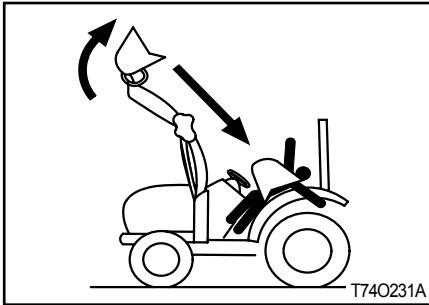

When attaching or detaching the loader, fix all parts which are connected to the bucket and boom. The bucket or boom can be accidentally dropped down, leading to an injury or even death.

### ► TOWING SAFELY

For the maximum towable loads, refer to the paragraph " Maximum towable loads in the Technical Data Section.

- Maintain a suitable speed taking into account the weight of the trailed load and the gradient, remembering that braking distances will be greater than with just the tractor. Trailed loads with or without brakes that are too heavy for the tractor or that towed at too high speed may cause the operator to lose control of the tractor.
- Always take into consideration the total weight of the implements and their loads.

### ⚠ CAUTION

- When a trailer is hitched to the tractor, before you leave the driving seat remember to put all the controls in neutral, apply the handbrake, switch off the engine, engage first gear (if the tractor has a mechanical transmission) and remove the key from the starter switch. If the tractor is not parked on level ground, **ALWAYS** place chocks under the wheels of both the tractor and the trailer. For further information on safe working procedures, refer to the chapter "Parking the tractor" in the safe section of this manual.



- When trailers are hitched to the tractor, before you leave the operator seat remember to put all the controls in neutral, apply the handbrake, switch off the engine, engage first gear (with mechanical transmissions) and remove the ignition key. ALWAYS chock both the tractor and the trailer wheels. The best way to transport a tractor that has broken down is to transport it on a low loader. Always secure the tractor to the loader bed with chains. Before transporting the tractor on a low loader or on a railway wagon, make sure that the engine hood, doors, openable roof (if present) and windows are all closed and securely fastened. Never tow the tractor at speeds in excess of 10 kph. An operator must stay in the operator position to steer and brake the tractor.

### ► FALLING OBJECT PROTECTIVE STRUCTURE (FOPS)

The term F.O.P.S refers to structure installed on the tractor intended to reduce the risk to the operator of injury from falling objects during normal use of the vehicle.

#### IMPORTANT

- This tractor is equipped with a FOPS.
- The energy level of drop test is 1365J.

### ► OPERATOR PROTECTIVE STRUCTURE (OPS)

The term OPS refers to a protective structure installed on a tractor in order to minimise risk of operator injury caused by objects penetrating into the operator position area.

#### DANGER

- This tractor is not equipped with an OPS. If work must be performed in areas subject to the risk of the penetration of objects into the operator position, consult your dealer before starting work so that the tractor can be equipped with an appropriate protective structure.





### ► SAFE OPERATION OF YOUR TRACTOR

The manufacturer of your tractor has made every effort to make it as safe as is humanly possible.

Beyond this point it is the responsibility of the operator to avoid accidents and we ask that you read and implement our suggestions for your safety.

Ensure that only trained and competent operators use this tractor and ensure that they are fully conversant with the machine and aware of all its control and safety features.

Operators should not operate the tractor or associated machinery while tired or untrained.

To avoid accidents please ensure that the operator wears clothing which will not get entangled in the moving parts of the tractor or machine and protect him or her from the elements.

When spraying or using chemicals, please ensure that clothing and protective equipment is worn which prevents respiratory or skin problems.

For full details consult the manufacturer of the chemicals.

To avoid lengthy exposure to noise ensure that ear protection is worn.

If adjustment to the tractor or machinery need to be made ensure the tractor or machine are turned off beforehand.

Use of certified Roll Over Protection Structure (ROPS) is a must while operating a tractor.

Use of seat belt is a must while operating a tractor.

In summary, ensure at all times that the safety of the operator and any other worker is paramount.

Ensure no one is between the tractor and a towed vehicle (trailer or implement).

### ► SAFETY TIPS DURING MAINTENANCE

1. At least on a daily basis check all oil levels. Water level in the radiator and electrolyte level in the battery and perform services according to the service schedule.
2. Ensure tire pressure are even and the correct pressure for the job being done is maintained.
3. Check to ensure that the all controls and preventative mechanisms of the tractor and implement work correctly and effectively.
4. Ensure that an adequate set of the correct tools is available for maintenance and minor repairs.
5. Ensure that all service work and repairs are carried out on a flat area with a concrete or similar floor.

Do not carry out service work on a tractor until it is switched off,



and the parking brake applied and wheels chocked.

Where a tractor is started in a confined area, ensure that the area is well ventilated as exhaust gases are very harmful, and can cause death.

6. Do not work under raised implements.
7. When changing wheels or tires ensure that a suitable wheel stand is placed under the axle prior to removing the wheel and the wheels are chocked.
8. Where guards or shields need to be removed to perform a service or repair, ensure that the guard or shield is correctly reinstalled before starting the tractor.
9. Never refuel near a naked flame or with an overheated engine. Ensure to turn off Engine before refueling.
10. The cooling system operates under pressure, take care when removing the radiator cap on a hot engine to prevent being scalded by steam or hot water. Do not add water in the radiator when the engine is hot. Add water to the radiator only after the engine cools down completely.
11. To prevent fires keep the tractor including the engine clean and free from inflammable material and well away from fuels and other inflammable material.

### ► MOUNTING AND DEMOUNTING IMPLEMENTS

1. Ensure that all mounting and removal of implements is done on safe flat ground. Ensure no one is between the tractor and implement and do not get under the implement to avoid accidental injuries.
2. After mounting the implement, ensure that all sway chains are correctly adjusted and, where PTO shafts are used that the shaft is fitted and secured correctly.
3. Where heavy implements are used, ensure that the combination is well balanced or use proper ballast to achieve balance.
4. Before leaving the tractor at any time, lower the implement, stop the PTO shaft where applicable, set the parking brake and switch off the engine.
5. While operating the implements with the PTO keep all bystanders away from any moving parts and do not attempt to make adjustments while the machine is running.



## SAFETY PRECAUTIONS

---

6. Only the driver should ride on the tractor with the ROPS frame fitted and with the seat belt properly fastened.
7. Where young children are present, particular care should be taken and the tractor should not be moved until the whereabouts of all children is known.
8. Only trained operators should operate the tractor and so taking care to ensure that other workers are not injured. In particular they should take care during dusty operations, which will reduce visibility substantially.
9. Never start the tractor unless the transmission is out of gear, the operator is in the seat and all round safety has been checked.
10. Only operate the tractor seated in the drivers seat and never turn or brake suddenly at high speed as this can cause a roll-over and serious injury or death.
11. When traveling on a public road ensure that the tractor and driver both meet all laws relating to safety and licensing. When traveling with wide implements use red flags on the extremities and observe all legal including escort requirements.
12. When operating under adverse conditions, hilly terrain or on bad ground adjust the speed of the tractor to suit the conditions, safety comes first. Never drive down hill at high speed or with the transmission in neutral. Use of the braking capacity of the engine as well as the service brakes.  
Do not try to change gear going up or down a steep slope, select the correct gear before starting.
13. Take care when traveling uphill with a heavy implement to ensure that it does not overbalance and tip up the front end.
14. Never remove or modify the seat belt.
15. Never remove, modify or repair the ROPS frame.

Please remember that a little bit of extra care can prevent serious injury or death and avoid damage to your tractor.



### ► THE FOLLOWING PRECAUTIONS ARE SUGGESTED TO HELP PREVENT ACCIDENTS

A careful operator is the best operator. Most accidents can be avoided by observing certain precautions. Read and take the following precautions before operating the tractor to prevent accidents.

Tractor should be operated only by those who are responsible and properly trained to do so.

### <THE TRACTOR>

1. Read the operator's manual carefully before using the tractor. Lack of operating knowledge can lead to accidents.
2. Use an approved rollover bar and seat belt for safe operation. Overturning of a tractor without a rollover bar can result in death or injury.
3. Do not remove ROPS (Roll Over Protective Structure). Always use the seat belt.

4. Fiberglass canopy does not give any protection.
5. To prevent falls, keep steps and platform clear of mud and oil.
6. Do not permit anyone but the operator to ride on the tractor. There is no safety place for extra riders.
7. Replace all missing, illegible or damaged safety signs.
8. Keep safety signs clean of dirt and grease.

### <SERVICING THE TRACTOR>

1. Keep the tractor in good operating condition for your safety. An improperly maintained tractor can be hazardous.
2. Stop the engine before performing any service on the tractor.
3. The cooling system operates under pressure, which is controlled by the radiator cap. It is dangerous to remove the cap while the system is hot. First turn the

cap slowly to stop and allow the pressure to escape before removing the cap entirely.

4. Do not smoke while the refueling the tractor. Keep away any type of open flame.
5. The fuel in the injection system is under high pressure and can penetrate the skin. Unqualified persons should not remove or attempt to adjust a pump, injector, nozzle or any part of the fuel injection system.

Failure to follow these instructions can result in serious injury.

6. Keep open flame away from battery or cold weather starting aids to prevent fire or explosions.
7. Do not modify or alter or permit anyone else to modify or alter this tractor or any of its components or any tractor functions.



### <OPERATING THE TRACTOR>

1. Before starting the tractor apply the parking brake, place the PTO (Power Take Off) lever in the “OFF” position, the hydraulic control levers in the downward position, the remote control valve levers in the neutral position (If fitted) and the transmission in neutral.

2. Do not start the engine or controls while standing besides the tractor. Always sit on the tractor seat when the engine or operating controls.

3. Safety starter switch.

In order to prevent the accidental starting of the tractor, a safety switch has been provided. The starting system of the tractor is connected through this switch, which becomes operative only when the clutch pedal is depressed. On some models shuttle shifter lever and PTO button should also be in neutral position for completing the

starting circuit. Do not bypass the safety starter switch. Consult your **Rural King** tractor Dealer/Distributor if safety- starting switch malfunctions.

4. Avoid accidental contact with the gear shifter lever while the engine is running. Unexpected tractor movement can result from such contact.

5. Do not get off or climb the tractor while it is in motion.

6. Shut off the engine, remove the key and apply the parking brake before getting off the tractor.

7. Do not operate the tractor in an enclosed building without adequate ventilation. Exhaust fumes can cause death.

8. Do not park the tractor on a steep slope.

9. If power steering or Engine seizes to operate, stop the tractor immediately.

10. Pull only from the swinging draw bar or the lower link drawbar in the down position. Use only a drawbar pin that locks in place. Pulling from the tractor rear axle carriers or any point above the rear axle may cause the tractor's front end to lift.

11. If the front end of the tractor tends to rise when heavy implements are attached to the three-point linkage, install front end or front wheel weights. Do not operate the tractor with a light front end.

12. Always use hydraulic position control lever when attaching equipments/implement and when transporting equipment. Be sure that the hydraulic couplers are properly mounted and will disconnect safely in case of accidental detachment of implement.

13. Do not leave equipment/implement in the raised position.



14. Use the flasher/ Turn signal lights and Slow Moving Vehicle (SMV) signs when driving on public roads during both day and night time, unless prohibited by law.
15. Dim tractor lights when meeting a vehicle at night. Be sure the lights are adjusted to prevent the blinding on the eyes of coming vehicle operator.
16. Emergency stopping instruction; If tractor fails to stop even after application of brakes. Pull the knob of fuel shut off control rod.

### <DRIVING THE TRACTOR>

1. Watch where you are going especially at row ends, on roads, around trees and low hanging obstacles.
2. To avoid upsets, drive the tractor with care and at speeds compatible with safety, especially when operating over rough ground, crossing ditches or slopes, and when turning at corners.
3. Lock the tractor brake pedals together when transporting on roads to provide proper wheel braking.
4. Keep the tractor in the same gear when going downhill as used when going uphill. Do not coast or free wheel down hills.
5. Any towed vehicle and/or trailer whose total weight exceeds that of the towing tractor, must be equipped with its own brakes for safe operation.
6. When the tractor is stuck or tires are frozen to the ground, back out to prevent upset.
7. Always check overhead clearance, especially when transporting the tractor.

### <OPERATING THE PTO>

1. When operating PTO driven equipment, shut off the engine and wait until the PTO stops before getting off the tractor and disconnecting the equipment.
2. Do not wear loose clothing when operating the power take-off or near rotating equipment.
3. When operating stationery PTO driven equipment, always apply the tractor parking brake and block the rear wheels from front and rear side.
4. To avoid injury, always move down flip part of PTO. Do not clean, adjust or service PTO driven equipment when the tractor engine is running.
5. Make sure the PTO master shield is installed at all times and always replace the PTO shield cap when the PTO is not in use.



### <DIESEL FUEL>

1. Keep the equipment clean and properly maintained.
2. Under no circumstances should gasoline, alcohol or blended fuels be added to diesel fire or explosive hazard. Such blends are more explosive than pure gasoline. In a closed container, such as a fuel tank. **DO NOT USE THESE BLENDS.**
3. Never remove the fuel cap or refuel the tractor with the engine running.
4. Do not smoke while refueling or when standing near fuel.
5. Maintain control of the fuel filler pipe when filling the tank.
6. Do not fill the fuel tank to capacity. Allow room for expansion.
7. Wipe up spilled fuel immediately.
8. Always tighten the fuel cap securely.

9. If the original fuel tank cap is lost, replace it with genuine cap. A none approved cap may not be safe.
10. Do not drive equipment near open fire.
11. Never use fuel for cleaning purpose.
12. Arrange fuel purchases so that winter grade fuel are not held over and used in the spring.

※N.B: It is suggested that after repairs if any of the Safety Decal/sign is peeled/defaced, the same may be replaced immediately in interest of your safety.

## 2. DO'S AND DON'T'S

### ► DO'S-FOR BETTER PERFORMANCE

- DO** - Ensure that safety shields are in place and in good condition.
- DO** - Read all operating instructions before commencing to operate tractor.
- DO** - Carry out all maintenance tasks without fail.
- DO** - Keep the air cleaner clean.
- DO** - Ensure that the correct grade of lubricating oils is used and that they are replenished and changed at the recommended intervals.
- DO** - Fit new sealing rings when the filter elements are changed.
- DO** - Watch the oil pressure gauge or warning light and investigate any abnormality immediately.
- DO** - Keep the radiator filled with clean water and in cold weather use anti-freeze mixture.



- Drain the system only in an emergency and fill before starting the engine.
- DO** - Ensure that the transmission is in neutral before starting the engine.
  - DO** - Keep all fuel in clean storage and use a filter when filling the tank.
  - DO** - Attend to minor adjustments and repairs as soon as necessity is apparent.
  - DO** - Allow the engine to cool before removing the radiator filler cap and adding water, remove the radiator cap slowly.
  - DO** - Shift into low gear when driving down steep hills.
  - DO** - Latch the brake pedals together when driving on a highway.
  - DO** - Keep draft control lever fully down when not in use.
- DON'TS-FOR SAFE OPERATION**
- DON'T** - Run the engine with the air cleaner disconnected.
  - DON'T** - Start the tractor in an enclosed building unless the doors and windows are open for proper ventilation.
  - DON'T** - Operate the tractor or engine while lubricating or cleaning.
  - DON'T** - Allow the tractor to run out of diesel fuel otherwise it will be necessary to vent the system.
  - DON'T** - Temper the fuel injection pump, If seal is broken the warranty becomes void.
  - DON'T** - Allow the engine to run idle for a long period.
  - DON'T** - Run the engine if it is not firing on all cylinders.
- DON'T** - Ride the brake or clutch pedal. This will result in excessive wear of the brake lining, clutch driven member and clutch release bearing.
  - DON'T** - Use the independent brakes for making turns on the highway or at high speeds.
  - DON'T** - Refuel the tractor with the engine running.
  - DON'T** - Mount or dismount from the right side of the tractor.
  - DON'T** - Temper the hydraulic control levers' upper limit stops.
  - DON'T** - Use draft control lever for lifting of implements.
  - DON'T** - Start the engine with the PTO engaged.
  - DON'T** - Use the governor Control Lever (Hand throttle) while driving on roads.
  - DON'T** - Move the hydraulic levers rearward.





# SAFETY PRECAUTIONS

## 3. SAFETY SIGNS

### ► GENERAL SAFETY INFORMATION

#### IMPORTANT

- This “General safety Information” should be kept with the machine at all times as reference data.

#### CAUTION

- This symbol means ATTENTION! YOUR SAFETY IS INVOLVED.

The message that follows the symbol contains important information about safety. Follow recommended precautions and safe operating practice.

### ► DECALS MOUNTING LOCATION

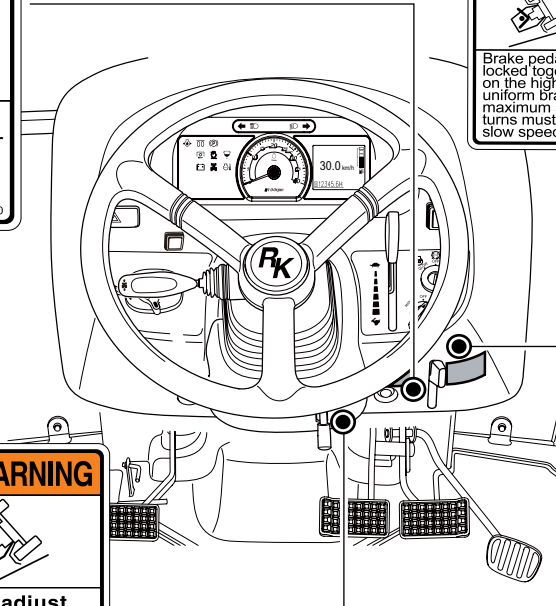
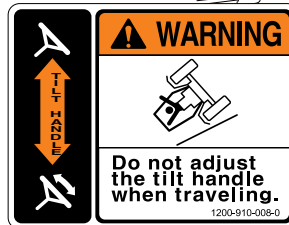
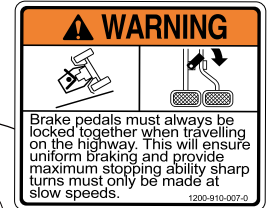



This ROPS was tested in accordance with AS1636.1-1996 and OECD Standard (Code 7) for use on the following Zetor tractor model: MAJORHS65 with a maximum weight (GVM) of 2600 kg

Manufacturer by Zetor

1220-904-077-1

**Inner/Outer air Ventilation**

- When grills of rear and both sides are opened, inner air will ventilate in.
- For effective use, open it when operate heater or air conditioner and close when ventilate fresh air.

1220-904-122-1

**WARNING**

Do not use the sub shift lever at "H" position when driving backward.

1200-910-001-0

**CAUTION**

Do not touch while the system is hot. It cause serious burns

1200-910-024-0

**WARNING**

Do not refuel the tractor while smoking or near naked flame or sparks. always stop engine before refueling tractors.

1200-910-005-0

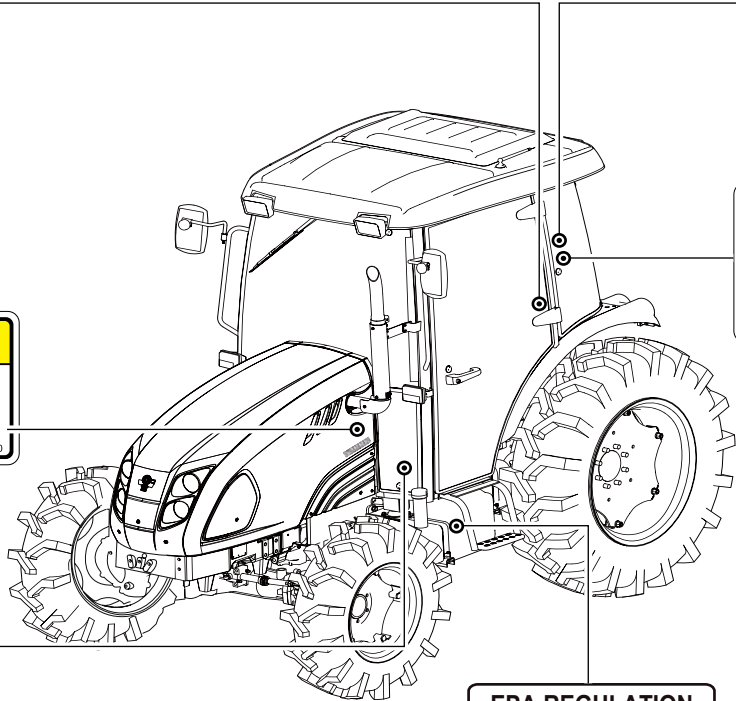

**EPA REGULATION**

**USE ULTRA LOW SULFUR FUEL ONLY**



# SAFETY PRECAUTIONS

**WARNING**



Work in ventilated Area.

1200-910-003-0



**!**



Operator's manual

1200-910-003-0

**! DANGER**

Periodic ventilation should be made to avoid suffocation while heating an air conditioning is used. Sleeping in the cab is prohibited.

1200-910-011-0

**WARNING**



Always fasten Your seat belt.

1200-910-019-0

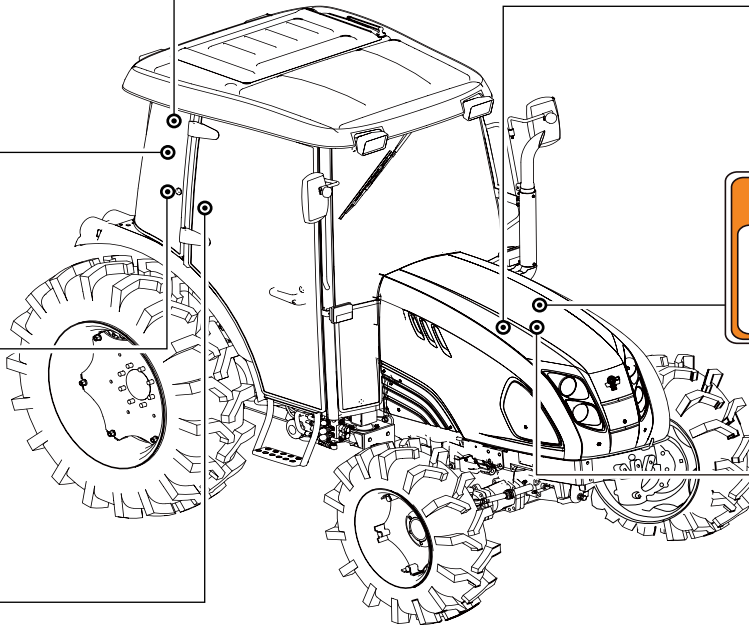

**WARNING**



Do not remove radiator cap while engine is hot. Hot steam will injure you.

1200-910-015-0

**CAUTION**

DO NOT OPEN THE RADIATOR CAP. HOT STEAM WILL INJURE YOU. REPLACEMENT OF THE COOLANT SHOULD BE DONE IN THE AUXILIARY TANK.

**CAUTION**

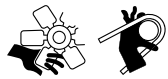

Keep hands and clothing away from rotating fan and belts to prevent serious injury.

1200-910-012-0

R740203A



**WARNING**

FAST SLOW (LOCK)

Always set the knob to lock when  
 1.Travelling on the road.  
 2.Replacing blades on an implement  
 3.Making adjustment to an implement  
 Sudden dropping of an implement  
 can cause serious injury or death.  
 1200-910-004-0

**Creep speed Operation!warning**

- Don't use creep speed as shown below works.
- 1)Tow Loads 2)Front loader 3)Blade work 4)Civil Engineering work 5)In & out the jobsite 6)Heavy industry
- Brake engagement at creep speed.
  - 1)Be sure to depress clutch pedal before depress brake pedal.
  - 2)Don't depress brake strongly as shaft reduction ratio of creep speed is very high and high torque.

**Front wheel drive shift lever**

ON  
OFF

**Creep speed shift lever**

ON  
OFF

**DANGER**

Do not ride except operator.

1200-910-016-0

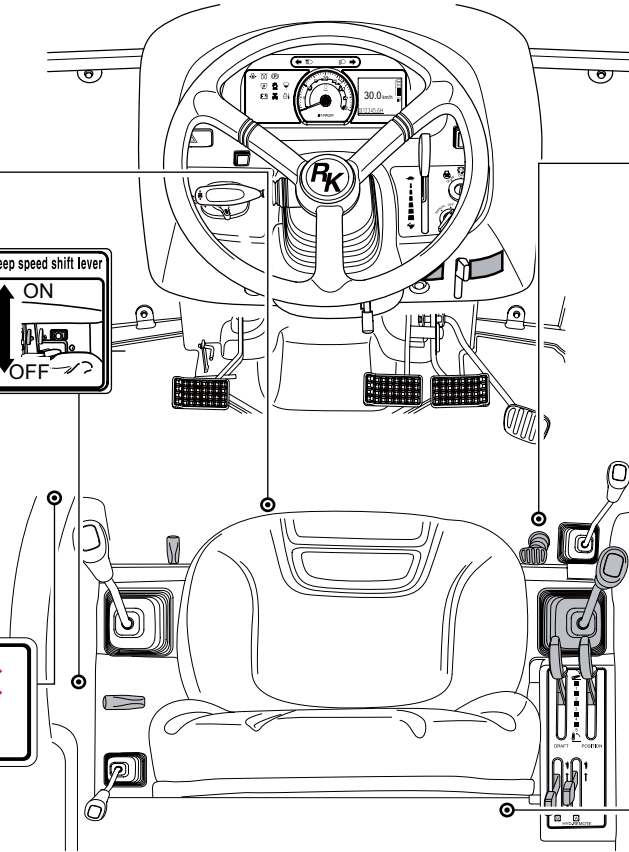

**WARNING**

Never use the diff-lock at high speed or on the road as this can cause rollover and injury.

1200-910-006-0

1768-920-005-0

**CAUTION**

**Remote hydraulic valve instruments**

REMOTE VALVE 'B' is "Floating Orient" TYPE  
 Remote valve couplers are numbered A and B from the bottom upward, and are operated by the corresponding remote control levers on the right hand.

- Always select "NEUTRAL" before starting the engine.
- Always select "NEUTRAL" after completing the hydraulic operation.
- Connect the implement to the remote couplers adequately.

PORT FLOATING TYPE: ACT. → N ← ACT.  
 SPRING TYPE: ACT. → N ← ACT.

Remote valve couplers      Remote control levers



## SAFETY PRECAUTIONS

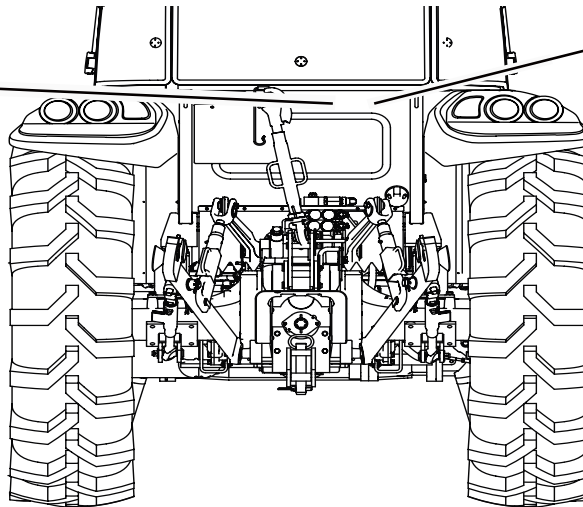
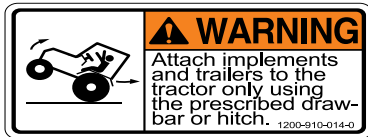



## 4. UNIVERSAL SYMBOLS

Some of the universal symbols have been shown below with an indication of their meaning.



Engine speed rev /  
min x 100)



Air filter



Power take off en-  
gaged



Parking brake



Hours, recorded



Battery charge



Power take off Dis-  
engaged



Work lamps



Engine coolant tem-  
perature



Pressured open slow-  
ly



Lift arm / raise



Differential lock



Fuel level



Continuous variable



Lift arm / lower



See operator's manual



Engine Stop control



Warning



Corrosive substance



Lights



Hazard warning



Transmission oil  
pressure



Horn



Neutral



Turn signal



Engine oil pressure



Fan



Transmission oil tem-  
perature





## **DESCRIPTION OF TRACTOR CONTROLS**

- 1. INSTRUMENT AND SWITCHES ..... 3-2**
- 2. OPERATION THE CONTROLS ..... 3-10**
- 3. OPERATING THE 3 POINT LINKAGE (TPL)..... 3-22**





## DESCRIPTION OF TRACTOR CONTROLS

### 1. INSTRUMENT AND SWITCHES

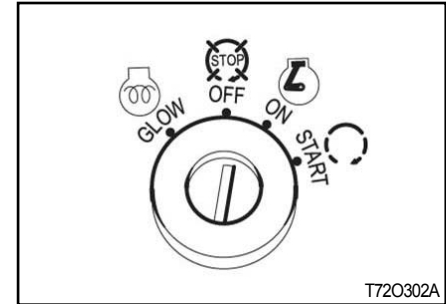
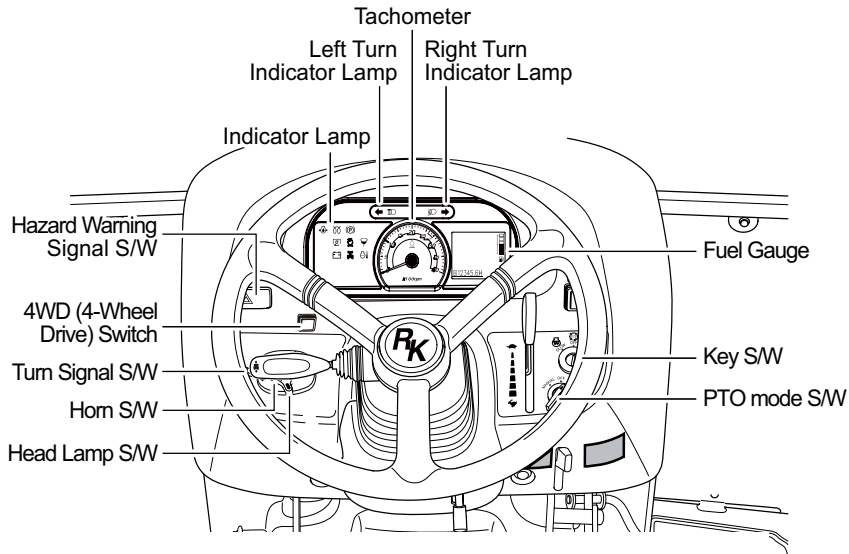

#### ► MAIN SWITCH

- OFF - The key can be inserted or removed.
- ON - The electric circuit is on.
- START - The starter motor is engaged. When the key is released it will return to the ON position.

R740301A

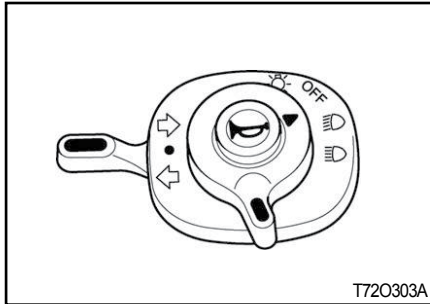

### ► LIGHT SWITCH, INDICATORS AND HORN

High and low beam are operated On the main switch.

- Position 1. High beam
- Position 2. Low beam

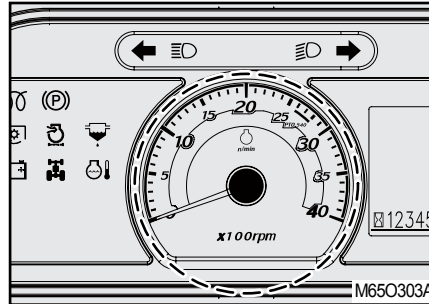

### ► TACHOMETER

This meter shows the revolutions of the engine and the PTO shafts as well as the travel speed in top gear.

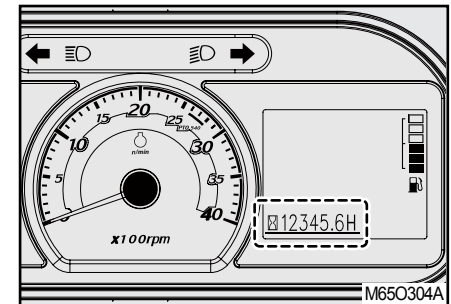

### ► HOUR METER

It indicates the total time of use. The last digit indicates one tenth hours. (decimal place) While the hour meter on the left most section is in operation, the lamp below it blinks.



## DESCRIPTION OF TRACTOR CONTROLS

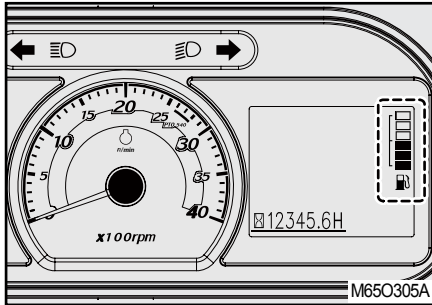

### ► FUEL GAUGE

Shows the amount of fuel in the tank when the ignition switch is "ON".

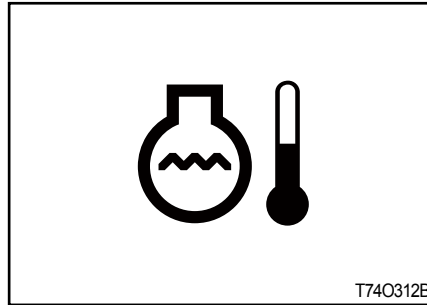

### ► WATER TEMPERATURE

This indicates the coolant temperature after the key switch is turned to the "ON" position.

When the lamp is comes on during driving, it means that the engine is overheated.

#### CAUTION

- Accelerating excessively rapid the engine can damage the engine.

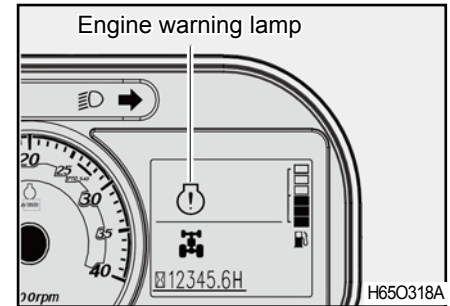

### ► ENGINE WARNING LAMP

It comes on when the engine is malfunctioning.

#### CAUTION

- When Engine warning lamp is it, ensure that you operator the tractor only after the engine RPM reaches at the normal speed. If this instruction is not kept, it may cause a performance degradation or accident due to a system error.



► WARNING LIGHTS

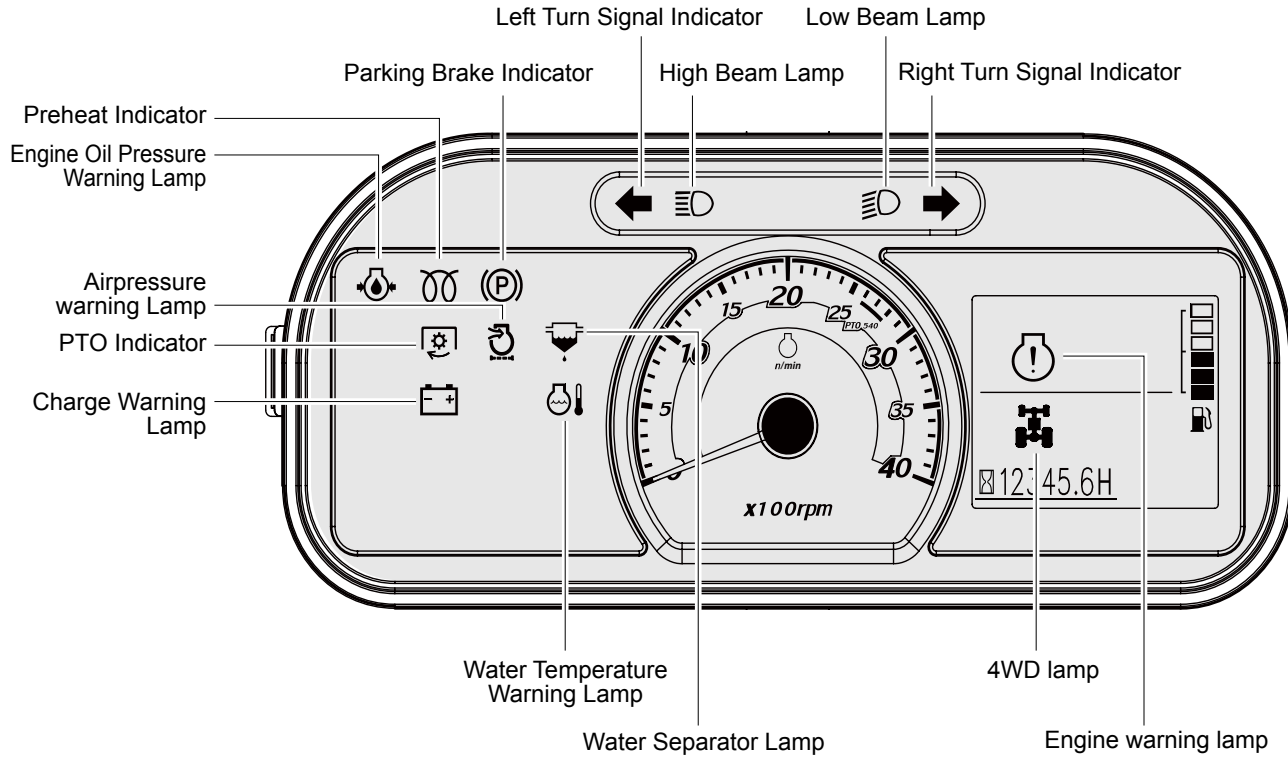



## DESCRIPTION OF TRACTOR CONTROLS

---



### Charge lamp

This light will go off as soon as the engine starts to run to indicate that the alternator is charging. (Please note, as broken fan belt can cause the light to come on, please stop the engine as overheating can occur if not rectified immediately)



### Oil pressure lamp

The lamp comes on when an engine oil lubrication problem occurs.

Stop the engine and check the engine oil level or get help from a workshop.



### PTO monitor Lamp

Shows the revolution of PTO. Refer to monitor lamp on Page 3-8.



### Air cleaner filter contamination indicator

This comes on when the air cleaner is clogged by foreign materials.

When this comes on, open the cover and clean the inside of the cleaner.

Also, blow air through the filter in the direction of intake air to clean it or replace the filter with a new one.



High beam lamp is operated on the combination switch.



Low beam lamp is operated on the combination switch.



Parking brake is operated when footbrake is engaged.



Fuel Level : If it comes on while the engine is running, Fill the tank with fuel.



Glow signal Lamp indicates preheating.



### 4WD drive lamp

4WD drive lamp is operated on when front-wheel drive is engaged.

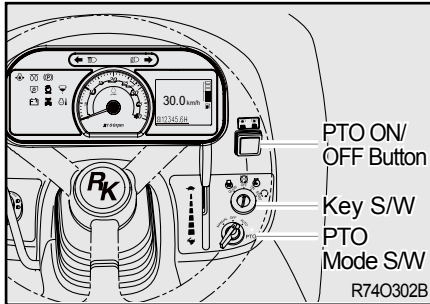

### ► INDEPENDENT PTO

It must be noted that the PTO shift lever on the LHS below the driver seat should be shifted to position 1 (540 RPM) or 2 (750RPM) depending upon the implement specification.

In no case the specified speeds be crossed as serious damage to the tractor/implement to person can result because of this.

When the PTO is not in use the shift lever must be put in neutral position to avoid unnecessary use or accidental use.

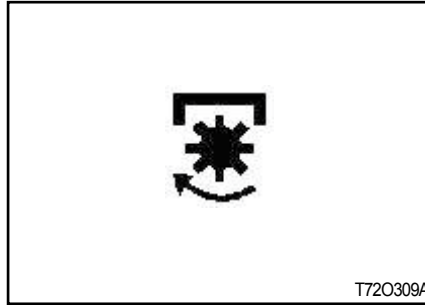

### ► THE PTO MONITOR LAMP

The PTO monitor lamp on the dash panel indicates the state of the PTO shaft.

1. If the monitor glows: The PTO is rotating.
2. If the monitor is off: The PTO is off.
3. If the monitor blinks: The PTO is presently stationary but will instantly start rotating of the clutch pedal is released or the implement is lowered .

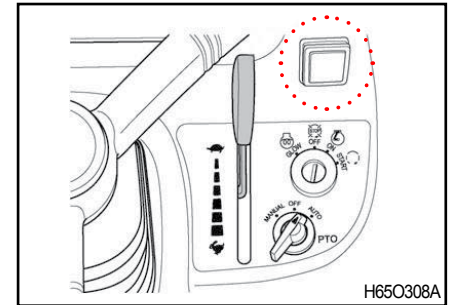

### ► PTO ON/OFF SWITCH

Two switches operate the independent PTO.

PTO "ON/OFF" switch: PTO "ON/OFF" switch is situated on the LHS. on the steering column and can be identified easily with its built in red colored indicator.

When the switch is pushed down to start the PTO indicator glows to indicate that the switch and the PTO are in "ON" position, If the switch is pushed down again the indicator goes off signaling that the PTO is "OFF".



## DESCRIPTION OF TRACTOR CONTROLS

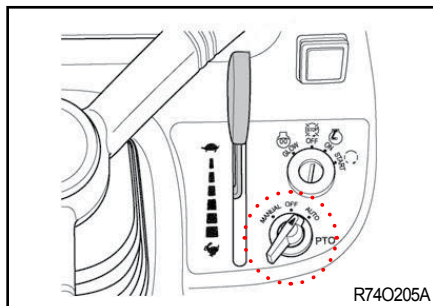

### ► PTO CONTROL SWITCH

This switch is situated near the starting key location on the dash panel. There are three positions marked for this switch.

- "Off" at the center.
- "Manual" at the left.
- "Auto" at the right.

The PTO shaft will not rotate if either of the two switches is in "OFF" position. The following table explains how the PTO operates at the two different (MANUAL & AUTO) positions of the PTO control switch with the PTO "ON/OFF" switch in the on position.

First select the specified speed for the PTO by using the PTO shifter on the LHS, below the driver seat.

PTO ON/OFF Switch	PTO Control Switch	Clutch Pedal	Hydraulic Position Control Lever	PTO Monitor Lamp on the dash panel	PTO Shaft
ON	Manual Mode	Either pressed or released	Either raised or lowered	Glow	Rotates
ON	Auto Mode	Pressed	Either raised or lowered	Blinks	Stationary
ON	Auto Mode	Either pressed or released	Raised	Blinks	Stationary
ON	Auto Mode	Released	Lowered	Glow	Rotates

- From the table above we learn about the safety features of the PTO. When the monitor on the dash panel is blinking it indicates to the operator that the PTO is in the "ON" position but temporarily not rotating either because the clutch pedal is pressed or the implement is lifted off the ground or both. The PTO will start rotating instantaneously when either the clutch pedal is released and/or the implement is lowered to the ground.
- The operator must use this blinking signal to clear the area around the tractor off bystanders/onlookers as the rotating blades of certain implements can accidentally cause injuries to the persons standing near the tractor.
- The stopping of the PTO when the implement is lifted off the ground with the position control prevents the damage to the implement or the PTO shaft.

**WARNING**

- When the PTO control switch is in manual position the PTO does not stop rotating even if the clutch pedal is pressed. If working on hard soils, pavements with a rotary implement the PTO "ON/OFF" switch must be put to the "OFF" position to stop the PTO from rotating , If this is not done the rotating blades of the implement will push on the hard ground below and in turn push the tractor toward causing accident which can lead to serious injuries or death.

**WARNING**

- Extra precaution must be taken to clear the area of bystanders/on-lookers when using PTO driven implements. The rotating blades of the implements can cause serious injuries on contact. The warning that is indicated by the blinking PTO monitor is to make the operator aware that the PTO is in on position and will instantly start rotating if the clutch pedal is released or implement is lowered or both.
- In no case the specified rotating speeds indicated by the implement manufacturer be crossed as the same can lead to serious damage to the tractor/equipment and can lead to serious injuries to persons around.





## DESCRIPTION OF TRACTOR CONTROLS

### 2. OPERATION THE CONTROLS

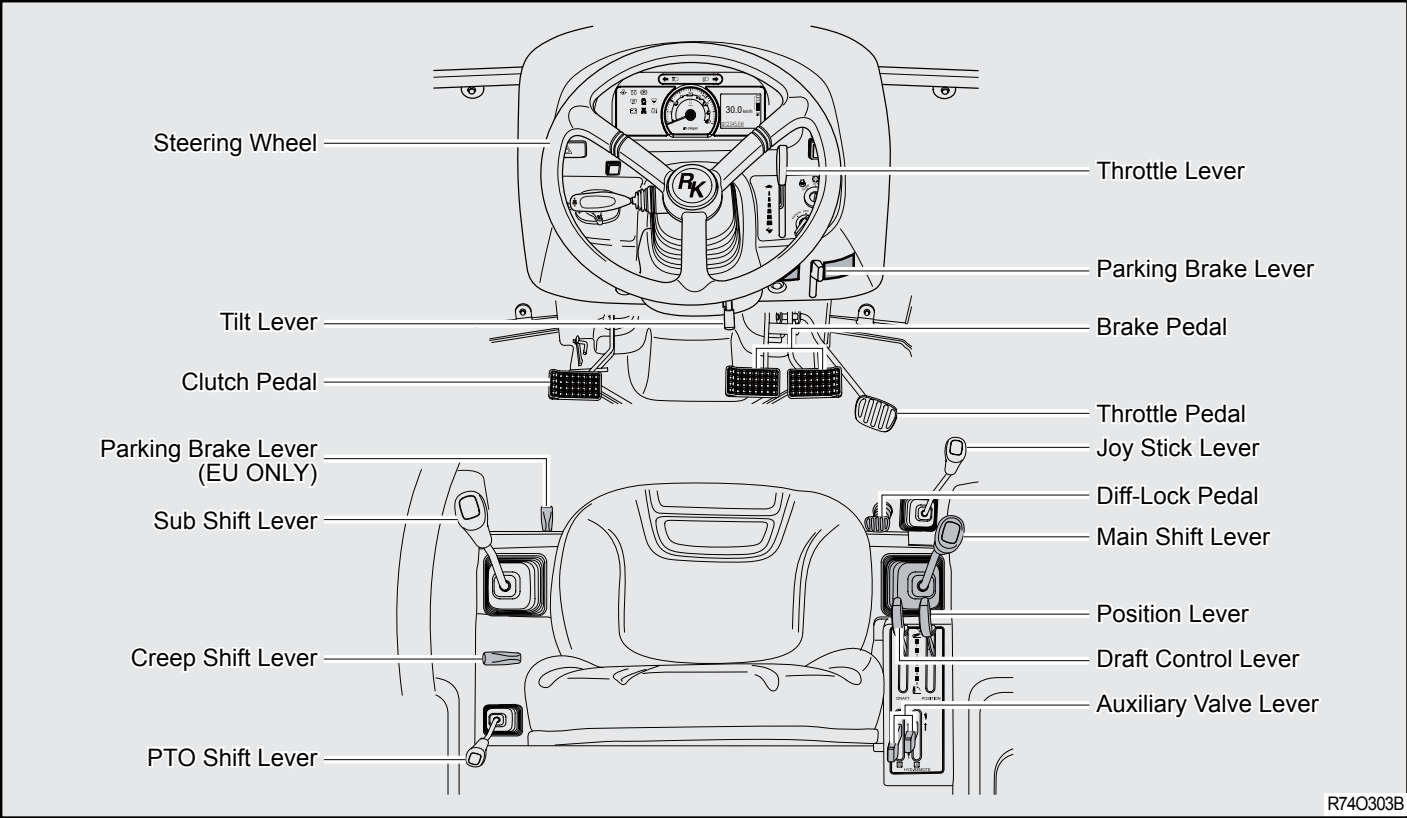

R740303B

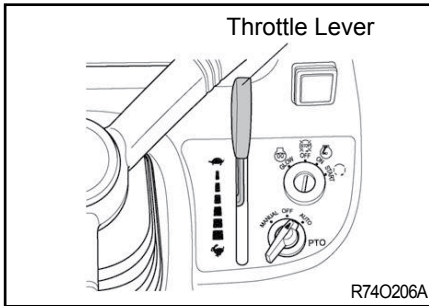

### ► HAND THROTTLE (THROTTLE LEVER)

Pulling the hand throttle towards the driver increases revolutions.

Pushing it away from the driver decreases revolution.

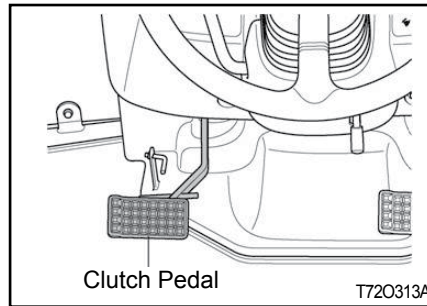

### ► CLUTCH DISCONNECTING ARM

For long term storage of the tractor it is possible to latch the clutch in the disengaged position.

Push the clutch down and engage the latch to hold it there.

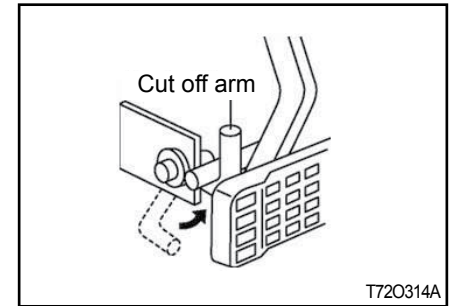

### ⚠ WARNING

- Do not attempt to start engine when this arm is being used.



## DESCRIPTION OF TRACTOR CONTROLS

### ► BRAKE PEDAL

Right and left brake pedals are provided to assist in turning the tractor in the field.

#### ⚠ CAUTION

- A connecting latch is provided to connect the right and left brake pedals for high speed or road use.
- In the interest of safety always use it on the road or at high speed as using one side only can cause rollovers.
- When servicing the tractor ensure that the adjustment on both sides is the same.

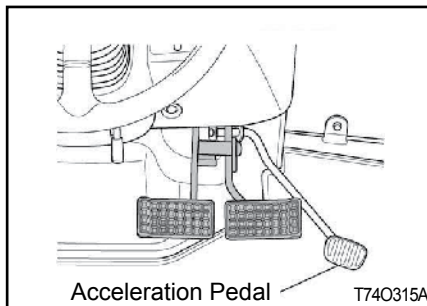

### ► FOOT OPERATED ACCELERATOR

This pedal can override a fixed hand throttle setting.

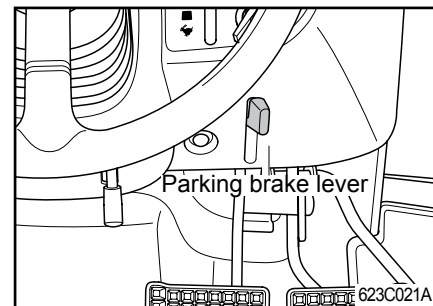

### PARKING BRAKE LEVER

1. With the left and right brake pedals interlocked, depress the brake pedal with a right foot firmly and pull up the parking brake lever to lock the pedals.
2. To release the parking brake, depress the brake pedal firmly.

#### NOTE

- The brake discs can be worn prematurely if driving the vehicle with the parking brake engaged partially.

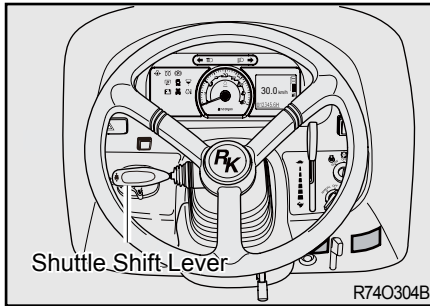

### ► SHUTTLE SHIFT LEVER - SC MODEL

This lever is to switch between forward driving and reverse driving. Set it in the position N unless driving.

- **Forward driving** - Pull up the lever and push it forward to drive forwards.
- **Reverse driving** - Pull up the lever and pull it backward to drive backwards. Then, the reverse driving buzzer sounds.

#### NOTE

- The vehicle can start off by operating the shuttle shift lever regardless of the position of the clutch pedal. Therefore, care should be taken.

#### ⚠ WARNING

- Do not operate the shuttle shift lever during driving. You can get injured by impact due to inertia. Change the driving direction after stopping the vehicle.
- Operate the shuttle shift lever only when seated in the driver's seat.

#### NOTE

The response speed can vary as follows according to the operating speed or operating environment (temperature) of the hydraulic clutch:

- Low operating oil temperature (in cold weather or initial tractor operation): The response may become faster (abrupt starting). Therefore, operate the clutch at a low speed, and operate the shuttle shift lever after warming up the engine sufficiently.
- High operating oil temperature (after prolonged use of the machine): The response may become slower, but this is normal.



## DESCRIPTION OF TRACTOR CONTROLS

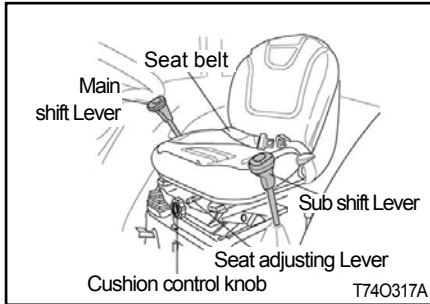

### ► MAIN GEAR LEVER

 This lever can be shifted by using the clutch, both when the tractor is stationary or mobile.

It is located on the R.H.S of the driver seat.

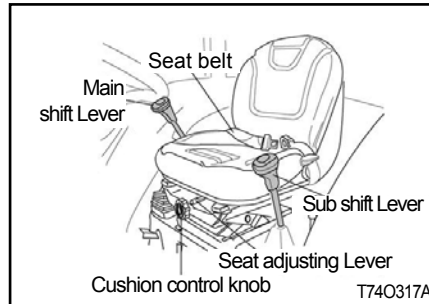

### ► SUB GEAR LEVER (LINEAR SHIFT LEVER)



Operate the sub gear lever using clutch to select the appropriate speed for different applications.

It is located on the LHS of driver seat.

### IMPORTANT

Avoid damage!

Select the proper speed range and gear for the job.

- The machine maybe operated in any gear with engine speeds at 945-2,200 rpm. Within these limits, the engine can be placed under varying load operations.
- Never overload engine by lugging machine at low idle speeds.
- Raise engine speed the match expected loads. If a slight increase engine rpm occurs simultaneously with moving hand throttle lever forward, the engine is not overloaded.



The sub shift lever (A) provides three speed ranges. The main shift lever (B) provides four gear positions. The reverse lever (C) controls travel direction.

Use all three levers in different combinations to achieve twenty four forward and twenty four reverse speeds.

Machine motion must stop and the clutch pedal must be depressed before changing ranges. Gear may be changed while machine is in motion if clutch pedal is completely depressed.

1. Choose a speed range to match work application:

A : Low speed/high power operations such as tilling hard soil, mowing high grass or positioning backhoe.

B : Operations including moderate tilling, hauling, and grass mowing.

2. Choose a gear that matches the immediate power/speed requirements:

- 1st Gear : High power, low speed operations.
- 2nd Gear : Medium power, moderate speed operations.
- 3rd Gear : Low power, moderate speed operations.

#### IMPORTANT

- Do not operate gear levers without stopping the tractor & without using the clutch.

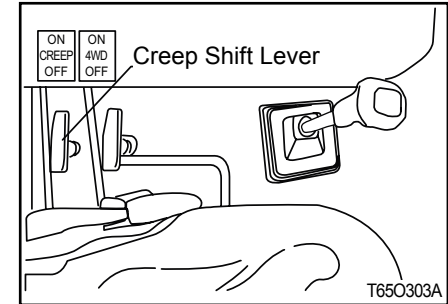

#### ► CREEP SHIFT LEVER

Shift the creep shift lever at "OFF" to high speeds and shift it "ON" to obtain low speeds.

The shifting requires clutch operation.

1. Creep speed (Attained by shifting the creep gear shift lever to ON) should be used only when doing one of the following jobs:

- Deep rotary-tilling and harrow
- Planting
- Turf application.



## DESCRIPTION OF TRACTOR CONTROLS

2. Creep speed should not be used for any of the following:

- Pulling a trailer
- Front loader operation
- Front blade operation
- Earth-moving
- Entering and leaving a field
- Loading onto and unloading from a truck

3. To avoid personal injury:

- When you leave the tractor, be sure to apply the parking brake and stop the engine
- In applying the brakes:
  - The torque of wheel axle is extremely high while creep speed is being used. Be sure to step down on the clutch pedal completely before applying the brakes, or they will not work.

- When starting to operate the tractor, be sure to release the parking brakes. Misuse of the brakes may cause damage to the transmission and is therefore not acceptable to **Rural King** for coverage under the warranty.

4. 'M' or 'H' of sub shift can not be engaged while the 'Creep' is on.

### IMPORTANT

- Press the clutch pedal completely down and stop the tractor's motion before shifting the creep speed gear lever.

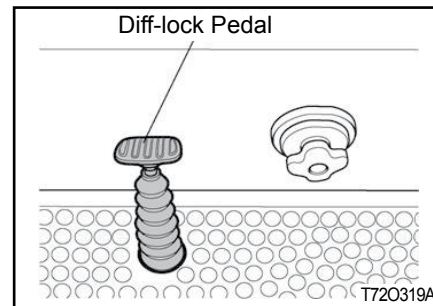

### ► DIFF-LOCK PEDAL

In case of wheel slippage use the diff-lock by pushing down on the diff lock pedal.

To release it remove the foot from the pedal.

### DANGER

- Tractor will be difficult to turn if the Diff-lock is engaged, ensure the lock is disengaged before turning the steering wheel.

**IMPORTANT**

- Do not use high engine RPM when engaging Diff lock. If the diff lock does not release after removing the foot from the diff lock pedal, alternatively brake with the left and right brake until it gets released.

**CAUTION**

- Never use the diff lock at high speed or on the road as this can cause roll over and injury.

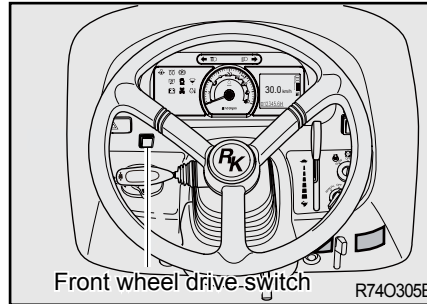
**▶ FRONT WHEEL DRIVE LEVER**

- ON - The 4WD function is activated when pressing the upper portion of the shift button.
- OFF - The 4WD function is deactivated when pressing the lower portion of the shift button.

**IMPORTANT**

- Do not use front wheel drive at high speed or on the road as premature wear of components will result.

**IMPORTANT**

- Always use the clutch when using the front wheel drive lever.

Use of front wheel drive improves traction performance.





## DESCRIPTION OF TRACTOR CONTROLS

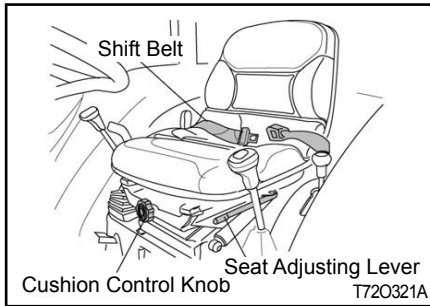

### ► DRIVER'S SEAT



To adjust the seat backwards and forwards lift the lever at the front of the seat and set it to the desired position.

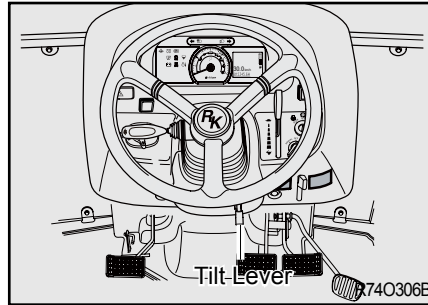

### ► TILT LEVER

To adjust the inclination of the steering wheel with a 3 stages and set it to the desired position.

**! DANGER**

- Ensure that the tilt pedal has locked before moving the tractor.

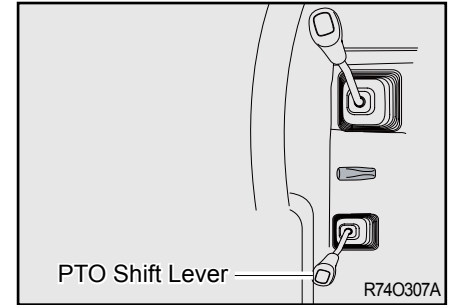

### ► PTO GEAR SELECTION LEVER

Your tractor is equipped with 2 Speed PTO to suit range of applications and conditions.

MODEL	POSITION	
	1st	2nd
RK74PSC	540	750



### IMPORTANT

- Always use the clutch when engaging or disengaging the PTO or changing PTO speed. Let the PTO driven implement come to a complete stop before changing.

### CAUTION

- Check whether the seat properly locked in its position before driving the tractor.

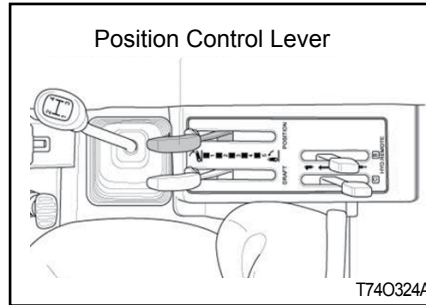

### ▶ OPERATING THE HYDRAULICS

The hydraulics are powered with an engine driven hydraulic pump and controlled with a position control lever mounted beside the driver.

### CAUTION

- When working with the 3-point linkage, keep well clear of the operating radius of the lift arms and any attached implement. This is to avoid the risk of injury in the case of incorrect manoeuvres.

### POSITION CONTROL

implements can be raised and lowered with the hydraulic position control lever and can be stopped at any position by stopping the lever.

To ensure a consistent working depth the adjustable stop can be set to ensure that the implement returns to the same depth every time.

- To raise the implement: Pull the lever back.
- To lower the implement: Push the lever forward.

### WARNING

- After finishing the work, always lower the implement to the ground and switch off the engine, Set the parking brake to avoid injuries and accidents.



## DESCRIPTION OF TRACTOR CONTROLS

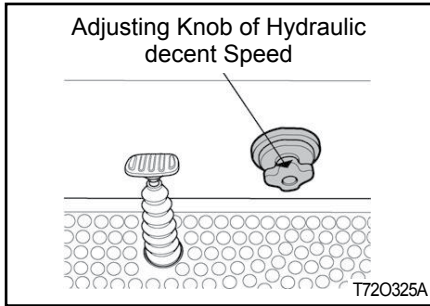

### ► LOWERING SPEED CONTROL KNOB FOR THE 3 POINT HITCH

This knob controls the downward speed of the hydraulics three point linkage and is positioned at the front of the driver's seat.

To slow the downward speed turn the knob clockwise.

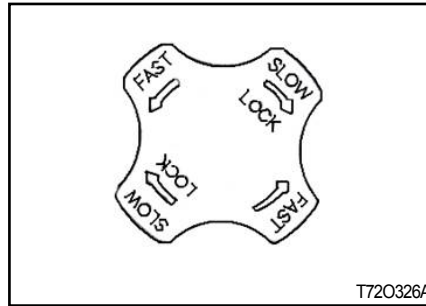

To increase the downward speed, turn the knob anticlockwise.

To lock the knob clockwise.

Do not over tighten the knob.

### ▲ CAUTION

Always set the knob to lock when

- Traveling on the road .
- Replacing tires or blades on an implement.
- Making adjustments to an implement. Sudden dropping of an implement due to hydraulic problems can cause serious injury or death.

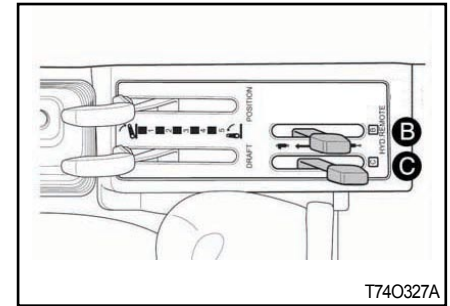

### ► EXTERIOR HYDRAULIC LEVER (OPTIONAL)

Move the lever up or down and hold. This will raise or lower the implement. (Rotavator or hydraulic plow)

Lever will return to neutral by itself.

**IMPORTANT**

- Do not hold the lever in the "Pull" or "Push" position once the remote cylinder has reached the end of the stroke. As this will cause oil to flow through the relief valve. Forcing oil through the relief valve for extended periods will overheat the oil.
- When Using the tractor hydraulic system to power front loader, do not operate the boom and bucket cylinders simultaneously.

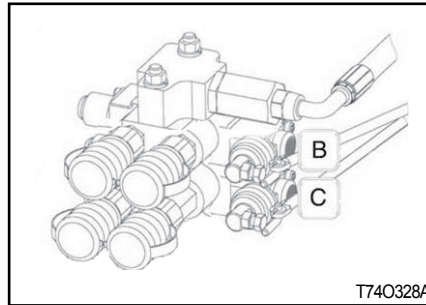
**▶ REMOTE HYDRAULIC CONTROL VALVE COUPLER CONNECTING AND DISCONNECTING****Connecting**

1. Clean both couplers.
2. Remove dust plugs.
3. Insert the implement coupler to the tractor hydraulic coupler.
4. Pull the implement coupler slightly to make sure couplers are firmly connected.

**Disconnecting**

1. Lower the implement first to the ground to release hydraulic pressure in the hoses.
2. Clean the couplers.
3. Relieve pressure by moving hydraulic control levers with engine shut off. Pull the hose straight from the hydraulic coupler to release it.
4. Clean oil and dust from the coupler, then replace the dust plugs.



## DESCRIPTION OF TRACTOR CONTROLS

### 3. OPERATING THE 3 POINT LINKAGE (TPL)

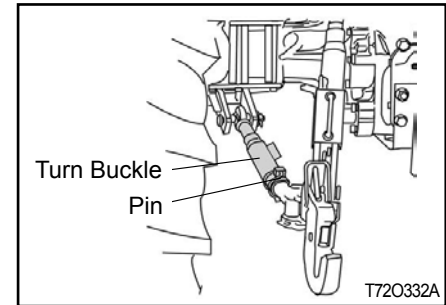
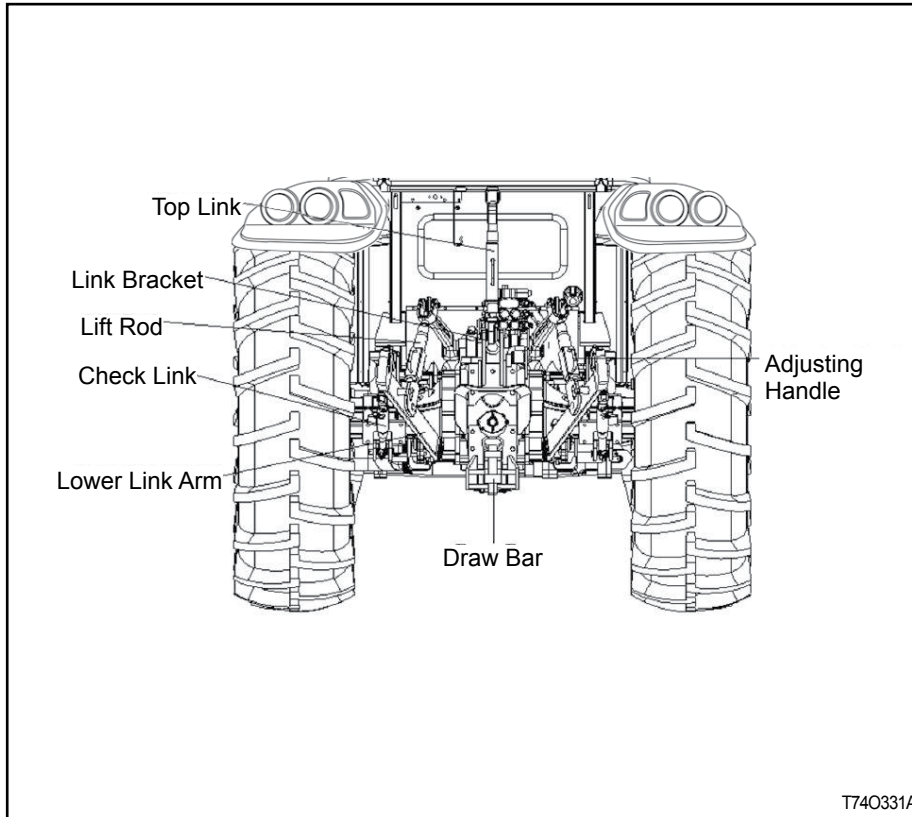

#### ► TURN BUCKLE STABILIZER ADJUSTMENT (CHECK LINK)

The stabilizers are intended for limiting or preventing implement side movement.

The length of stabilizers is adjusted by removing the pin and rotating the turn buckle barrel by which the threaded ends are interconnected.

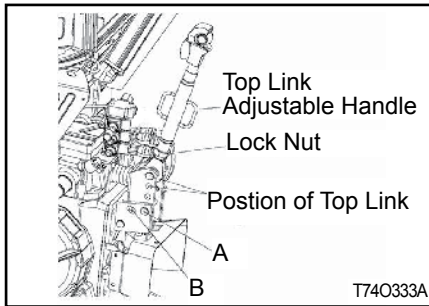

### ► ADJUSTMENT OF THE TOP LINK

Lengthening or shortening the top link will change the angle of the implement.

The locating hole of the top link varies with the type of implement used.

The most common locations are the 1st and 2nd hole from the top.

- For general implement: Use the Pin to "A": point
- For Draft control: Use the Pin to "B":point

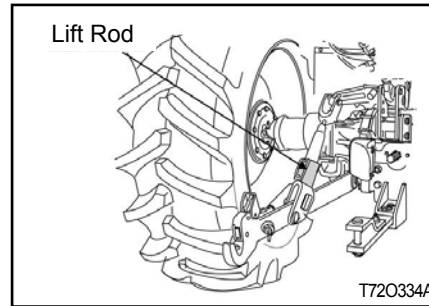

### ► ADJUSTMENT OF THE LIFT ROD (LEFT, RIGHT)

Adjust the length of the lift rod by screwing the adjustable.

Handle in or out. Adjust the length of the lift rod as necessary to set the implement in its working position parallel to the ground.

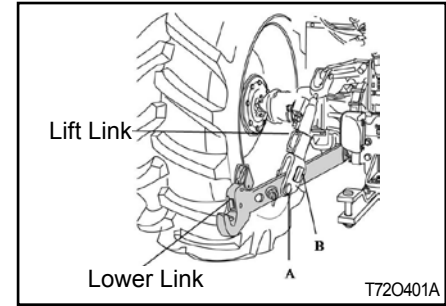

### ► ADJUSTMENT OF THE LIFT LINK ON THE LOWER LINK

For different applications change the position of the yoke rod on the lowerlinks as shown. There should be no clearance (Position "A") during implement transport and when working with grades, rollers, mowers, seeders, drills and similar implements. However, a slight play is necessary (Position "B") when working with ploughs, Harrows, ditchers, cultivators and the like: that is when working with "Draft control".



## DESCRIPTION OF TRACTOR CONTROLS

---

- For general implement: Use the Pin to "A" point.
- For Rotary tilling: Use the Pin to "B" point.

### DANGER

- Only use drawbar to tow and keep the 3 point linkage in raised position when towing with the drawbar.
- Position can create unbalance causing the tractor to roll-over & result the death or serious injury.

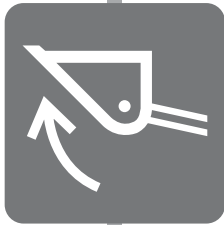

## OPERATION

1. STARTING THE ENGINE .....	4-2
2. STOPPING THE ENGINE .....	4-3
3. DRIVING THE TRACTOR.....	4-3
4. CONNECTING AND DISCONNECTING IMPLEMENT .....	4-10





### 1. STARTING THE ENGINE

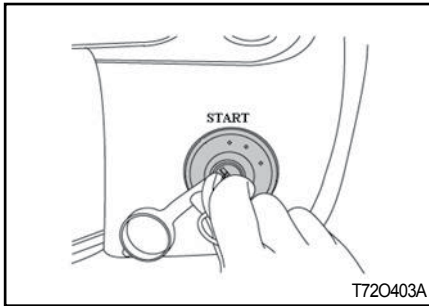

Before starting the engine carry out the pre-operational checks as set out on page 2-10.

1. Sit on the driver seat.
2. Apply the footbrake.
3. Put the hydraulic lever in the down position.
4. Push down the clutch pedal to activate the safety-starting switch.
5. Put the main gear lever in neutral.
6. Insert the ignition key and turn it on.

7. Ensure that the warning lights are working.
8. Always turn the ignition key to right for a moment & release it.  
The automatic heater will start working as will be indicated by a light on the instrument panel .As the lamp goes off turn the key to the start position to start the engine.
9. Ensure that all the warning lights are off with the engine running.

#### **IMPORTANT**

- Never turn the key to the start position while the engine is running as this can cause serious damage to the starter and engine flywheel.
- Only engage the starter for a period of not more than 10 seconds.
- If Engine does not start, rest the starter for about 20 seconds and try again for a maximum of 10 seconds. If the engine does not start after repeated attempts, refer to the fault tracing guide.
- Especially in cold weather, always allow the tractor to idle for a while to warm up & build up sufficient oil pressure to ensure normal operating temperature for longer engine life.



## 2. STOPPING THE ENGINE

After light work let the engine idle for a while and turn the key off.

### IMPORTANT

- After long or heavy work allow the engine to idle for 5- 10 minutes and turn the key off.

## 3. DRIVING THE TRACTOR

### ► WARMING UP

When starting the engine allow it to warm up to operating temperature by allowing it to idle 5-10 minutes to ensure full lubrication and operating temperature.

Failure to do so can shorten engine life substantially.

### WARMING UP IN COLD WEATHER

Cold weather will change the viscosity of the oil, resulting in a reduced oil pumping capacity, which can cause damage to the engine if it is not warmed up correctly.

It also causes problems with the hydraulic system and the synchromesh in the transmission.



### WARMING UP TIME

Temperature	Time for warming up
Above 50°F	5~10 min.
50°F~ 32°F	10~20 min.
32°F~14°F	20~30 min.
14°F~-4°F	30~40 min.
Below -4°F	Over 40 min.

#### IMPORTANT

- Ensure the handbrake (Foot brake) is on during the warming period.
- Failure to warm up correctly can result in problems.

When the engine is warm push down the clutch and engage the main and auxiliary gear levers to the required position.

Push down on the brake pedals and release the handbrake.

Increase the engine revolutions and let out the clutch smoothly.

Only change gears with main gear lever while moving and ensure that this is done with fully use of the clutch.

#### CAUTION

- Do not "ride" the clutch to control speed, use a lower gear.
- Do not travel with your foot on the clutch pedal.

#### DANGER

- Always connect the brake pedals when traveling on the road.
- Never tow anything except with the drawbar.
- Do not tow loads which are too large for the tractor's capacity to brake effectively especially in hilly terrain.
- Take special care when towing large or wide implements.
- Do not carry passengers.
- At all times observe local legislation and road rules.

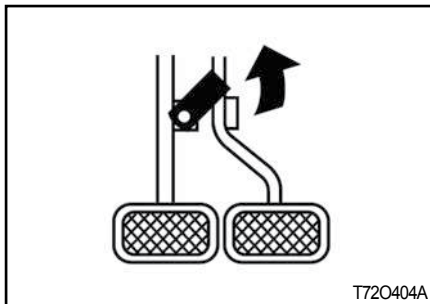

#### ► TIGHT TURNS IN THE FIELD

Disconnect the latch connecting left and right brake pedals to allow the use of individual pedals.

To make a tight turn use both the steering wheel and the brake pedal at the same time.

For a left turns use the left pedal and a right turn the right pedal.

#### ▲ CAUTION

- Perform tight turns only at a slow safe speed.
- Doing so at a high speed can cause rollovers and very serious injury or death.

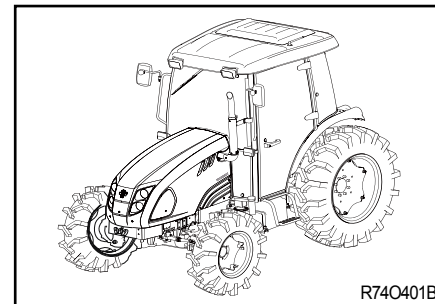

#### ► NORMAL BRAKING AND PARKING

Let the engine come back to idle and at the same time push in the clutch and brake simultaneously.

When the tractor has come to a halt, lower any implement to the ground, and put the main gear in neutral.

Apply the park brake, stop the engine, and remove the key.



### CAUTION

- Always apply the park brake when parking.
- Failure to do so can cause accidents and damage.
- As an extra precaution when parking on a slope, chock the rear wheels.

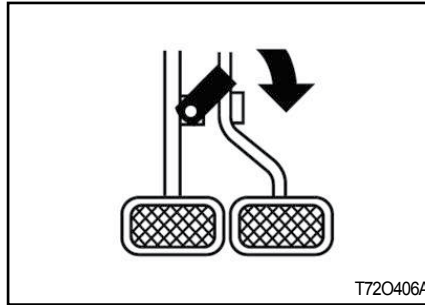

### ► UPHILL STARTS ON A STEEP SLOPE

With the pedals connected together push down on the brake pedals and push down the clutch.

Set all gear levers to low and the throttle to medium engine speed.

Release the clutch and as it engages release the brake pedals.

Adjust the throttle to the required speed.

### DRIVING DOWNHILL

Use the engine's ability to brake when traveling downhill.

Never rely on the brakes only and never travel downhill with the gears in neutral.

### CAUTION

- When operating in hilly terrain the risk of the rollover is increased substantially, please drive with extra care.
- When towing trailers in hilly terrain ensure that they are equipped with brakes, use a lower gear to get maximum engine braking and do not change gears on a down hill run.



### ► OPERATION OF THE DIFF LOCK

While the diff lock is a very useful feature, care should be taken in its use as misuse can lead to dangerous situations.

The diff lock would only be used in situations where traction is lost on one of the rear wheels.

#### WARNING

- Use low engine revolutions when using the diff lock.
- If the diff lock does not release after removing the foot from the pedal use the left and right brake pedals in turn to release it.
- Do not try to engage or use the diff lock on tight turns as serious damage can result.

### ► CHECK DURING DRIVING

Constantly monitor the warning lights on the dash and if any comes on stop the tractor to determine the cause.

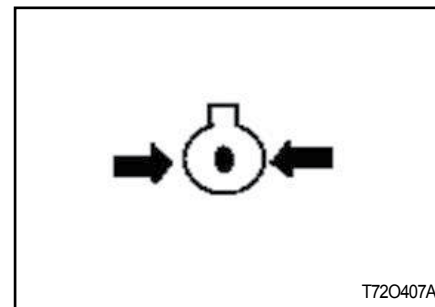

### OIL PRESSURE LIGHT

If the oil pressure light comes on check the oil level first of all.

If the oil level is OK ask a qualified dealer to check the reason for the light coming on.

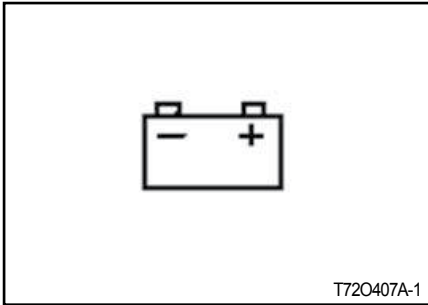

### BATTERY CHARGING

If the alternator warning light comes on check all connections and ensure that the fan belt is not broken.

If all connections and the fan belt are intact consult your dealer to determine the cause of the problem.

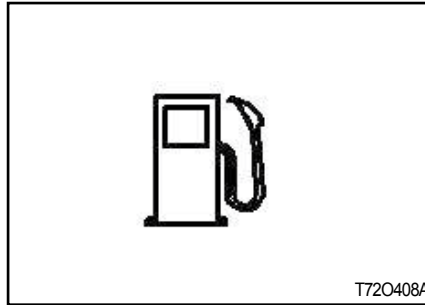

### FUEL GAUGE

To avoid excessive condensation in the fuel tank refill at the end of each day's work and ensure during the day that it does not drop to a low level where the fuel system will require bleeding to expel air in the system after refilling the tank.

### ► CHECK DURING DRIVING

As RK74PSC models of **Rural King** are front wheel assist the front track can be set in 2 positions. The rear track can be set in 4 positions as illustrated.

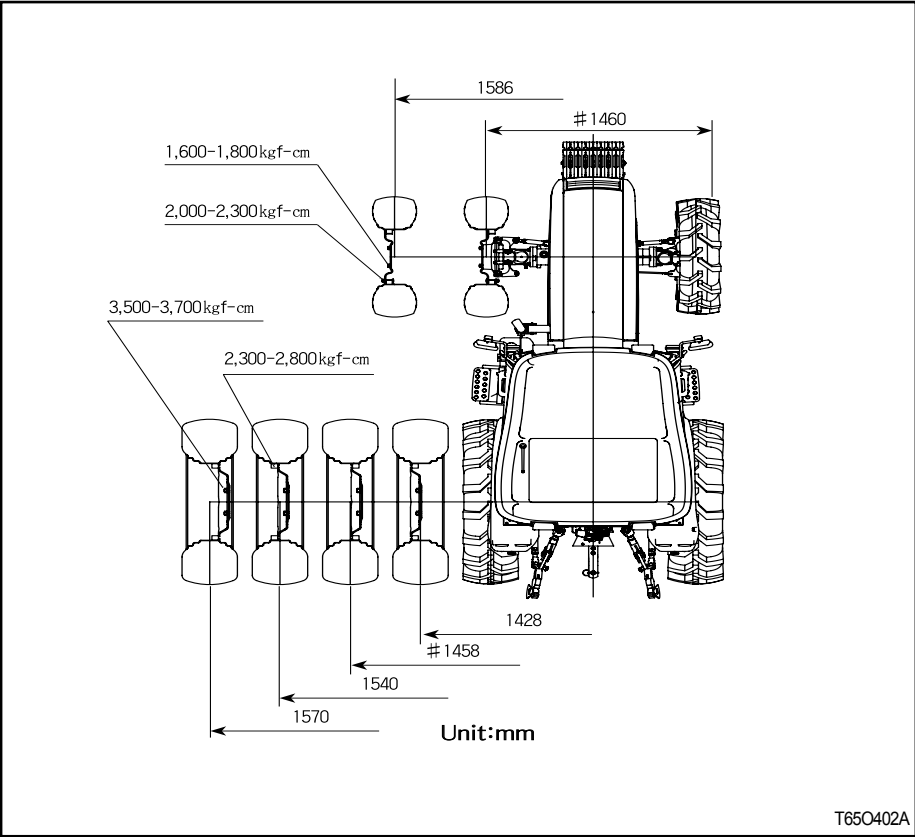





### 4. CONNECTING AND DISCONNECTING IMPLEMENT

#### CONNECTION

1. Make sure to stop the engine before connecting it.
2. Move the double acting valve lever forward and backward for 4 to 5 times to release the pressure in the hydraulic line of the tractor. Otherwise, it is hard to connect the couplers, and hydraulic fluid can be sprayed from the line and get in to your eyes while connecting them.
3. Remove any foreign material around the male and female couplers. If foreign material enters the hydraulic components, it can lead to malfunction of the system.
4. Open the dust-proof cover of the female coupler of the tractor and insert the male coupler of the implement. A clicking sound is heard when the couplers are engaged.
5. Pull the hydraulic hose of the implement to check that the couplers are properly connected.

6. Start the engine and check the operating status and leakage.

#### DISCONNECTION

1. Make sure to stop the engine before disconnecting it.
2. Release any residual pressure in the hydraulic hoses of the implement and tractor by operating the double acting valve lever 4 to 5 times.
3. Remove any foreign material around the couplers.
4. Keep the implement balanced by removing any load applied (lowering it onto the ground, for example). If disconnecting the hose while outer load is applied to the implement, it is hard to connect the implement in the future.
5. Remove the male coupler by pushing the female coupler boss of the tractor backward.

6. Close the dust-proof cover of the female coupler of the tractor. Wrap the male coupler of the implement with a plastic bag to prevent contamination.

#### WARNING

- Never connect or disconnect the implement hydraulic hose while the pressure in it is not released or the engine is running. It is hard to connect and disconnect the hose and hydraulic fluid can be sprayed from the hose, and get into your eyes or skin.
- Stop the engine and wear protective glasses and gloves before work.

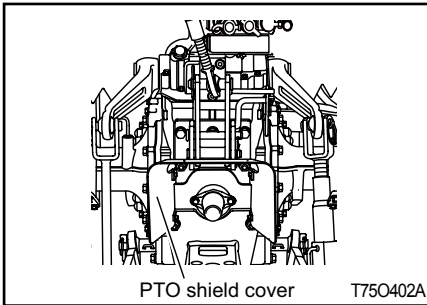

### ► MOUNTING IMPLEMENT

If the PTO is used, remove the safety cover off the PTO shaft.

Adjust the yoke rod on the lower links to suit the implement in use.

Attach the left lower link, then attach the right lower link using the adjusting handle on the leveling box if required.

Attach the top link.

Attach the PTO shaft to the tractor if used, making sure that it is locked in place.

Adjust the check chains to suit the implement and tighten the locknuts.

To remove an implement reverses the procedure.

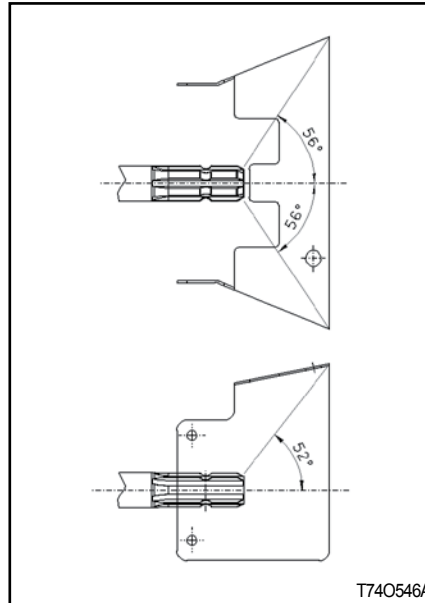

### ▲ CAUTION

- Do not attach a PTO shaft with the engine running and ensure all safety shields are in place.

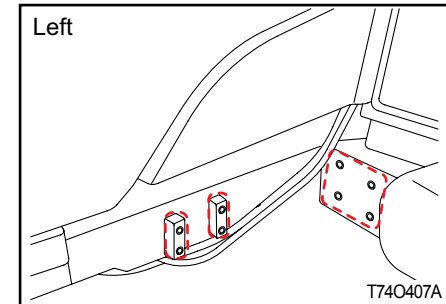
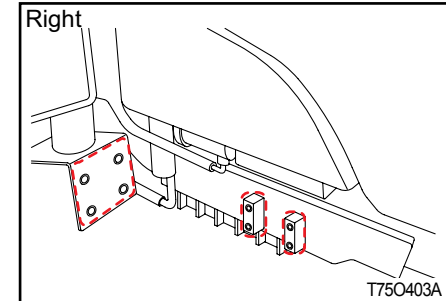

### ► FIXATION POINTS OF LOADER

- Screw size : M16 X 2
- Screw strength : 9T
- Number : 20



# OPERATION

---

## MEMO

A series of horizontal dotted lines for writing a memo.

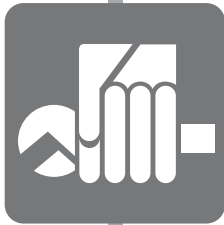

## **MAINTENANCE**

<b>1. CHECKS AND SERVICE .....</b>	<b>5-2</b>
<b>2. MAINTENANCE AND ADJUSTMENT SCHEDULE....</b>	<b>5-7</b>
<b>3. TIRE SIZE AND INFLATION PRESSURE .....</b>	<b>5-9</b>
<b>4. FILLING DIAGRAM &amp; CAPACITY TABLE .....</b>	<b>5-10</b>
<b>5. LUBRICANTS .....</b>	<b>5-11</b>
<b>6. OPENING METHOD OF EACH COVER .....</b>	<b>5-12</b>
<b>7. BLEEDING THE FUEL SYSTEM.....</b>	<b>5-13</b>
<b>8. CHANGING THE OILS IN THE TRACTOR .....</b>	<b>5-14</b>
<b>9. CLEANING AND CHANGING FILTERS.....</b>	<b>5-17</b>
<b>10. CHANGING THE COOLANT .....</b>	<b>5-20</b>
<b>11. GREASING THE TRACTOR.....</b>	<b>5-22</b>
<b>12. GAP ADJUSTMENT .....</b>	<b>5-23</b>
<b>13. BATTERY MAINTENANCE .....</b>	<b>5-25</b>
<b>14. OTHER MAINTENANCE .....</b>	<b>5-27</b>
<b>15. STORAGE.....</b>	<b>5-30</b>
<b>16. FUEL SAVING TIPS.....</b>	<b>5-32</b>



## 1. CHECKS AND SERVICE

### ► GENERAL INFORMATION

This section gives full details of the service procedures necessary to maintain your tractor at peak efficiency while the lubrication and maintenance chart provides a ready reference to these requirements.

### PRE-START CHECKS

To avoid problems it is recommended that a range of checks be carried out daily before starting the tractor.

For full details of the items and frequency please refer to the tables on page 5-7, 5-8, 5-9 and 5-10.

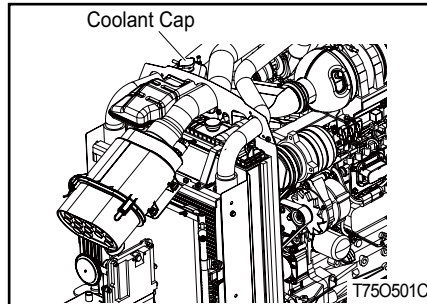

### ► CHECKING ENGINE COOLANT

#### INSPECTION

Check that the coolant level in the reservoir is between the MAX. and MIN. levels. If insufficient, add coolant to the reservoir.

#### ⚠ WARNING

- Do not open the cap when the engine is hot. Otherwise, hot steam can burn you seriously. Wait until the engine is sufficiently cooled down.

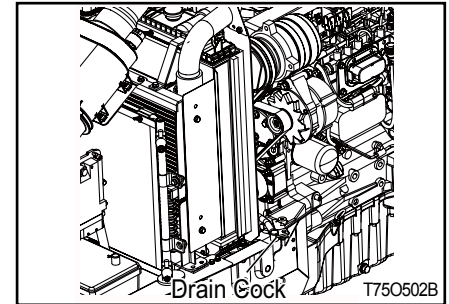

If the coolant is a rusty color, drain the system completely and refill with the correct mixture of water and anti-freeze or corrosion inhibitor.

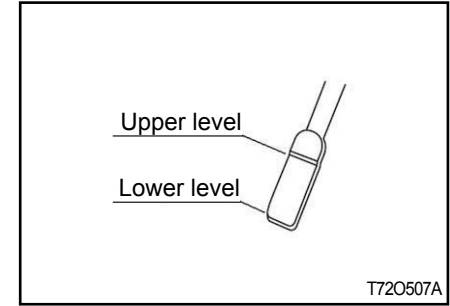
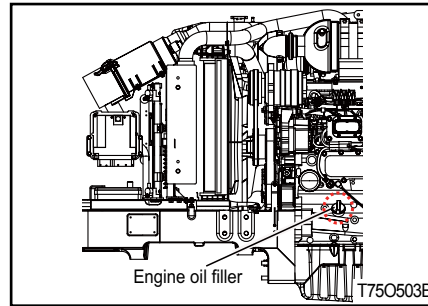
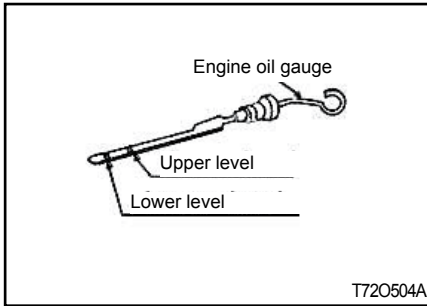

► **ENGINE OIL**

Pull out the stick, wipe it and dip in the oil sump.

Ensure that oil level is between the upper and lower mark near the upper mark. If too low add oil, but never excess 100 hrs.

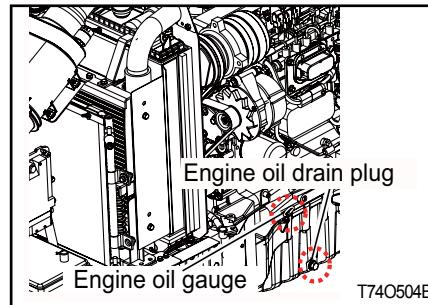

► **TRANSMISSION OIL**

Check the level with the dipstick on top of the transmission in rear of the seat.

If the level is low add oil through the filler hole.

**IMPORTANT**

- Do not overfill the crankcase with oil.

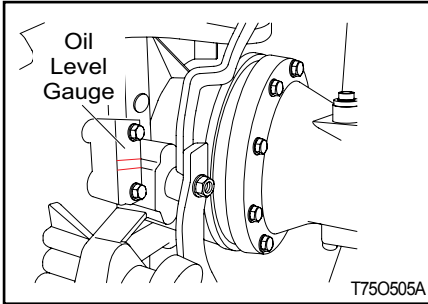
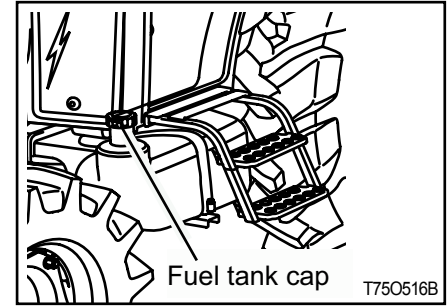
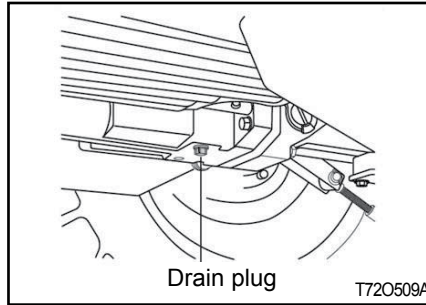
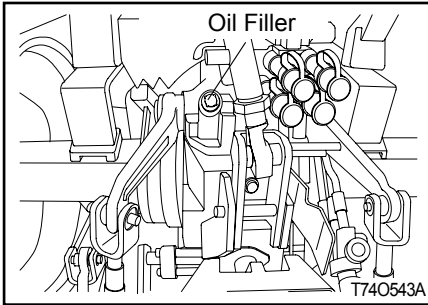

**CAUTION**

- Always ensure that you use the correct oil for topping up or oil changes.

**► FUEL**

Use the fuel gauge to check the fuel level and top up if too low.

It is a good practice to refill the tank immediately after use to avoid condensation.

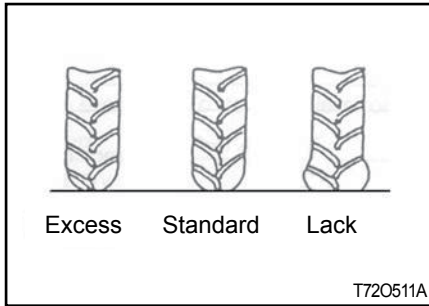

► **TIRE PRESSURE**

The air pressure used in the tires has a direct bearing on the life of the tire and its performance in the field.

Ensure that the tire pressures are correct and in accordance with the table on page 5-11.

To make a visual judgment see the drawing on the right.

**IMPORTANT**

- It is strongly recommended that tire pressures are checked with a proper gauge only & visual inspections are relied upon.

**DANGER**

- Excess tire pressure can cause accidents!

► **STEERING**

Ensure that the steering wheel does not have excessive free play.

► **BRAKE**

Ensure that the left and right brakes are adjusted correctly so they operate simultaneously. The correct free play on the brake is 1.18~1.57in. (30~40 mm)





### ► CLUTCH

Ensure that the clutch is adjusted correctly.

Correct free play on the clutch pedal is 0.78~1.18 in. (20~30mm)

#### CAUTION

- Incorrect clutch adjustment can cause excessive wear and reduced tractor performance.

### ► ELECTRICAL

Check the operation of all gauge, switches, horn, lights and indicators.



## 2. MAINTENANCE AND ADJUSTMENT SCHEDULE

### ► PERIODICAL CHECK AND SERVICE TABLE

**⚠ CAUTION**

- These intervals are for operation under normal conditions and need to be reviewed under severe conditions to a greater frequency.

○ Check, Top-up or Adjust, ● Replace, △ Clean or Wash, ★ First Replacement

No.	Item	Daily	Service interval(Hour meter,Mark)													1Year	2Year
			50	100	150	200	250	300	350	400	450	500	550	600			
1	Engine oil & Cartridge	○	★										●		●		
2	Air cleaner					○						●					
3	Radiator coolant	○														●	
4	Fuel	○															
5	Fuel filter (A) Main	○										●			●		
6	Fuel filter (B) Pre	○										●			●		
7	Fan belt	○										○					
8	V-belt	○										○					
9	Battery			○													
10	Loose nuts and bolts	○															
11	Radiator hose clamp	○															
12	Transmission oil & cartridge		★					○					●		●		



# MAINTENANCE

○ Check, Top-up or Adjust, ● Replace, △ Clean or Wash, ★ First Replacement

No.	Item	Daily	Service interval(Hour meter,Mark)												1Year	2Year
			50	100	150	200	250	300	350	400	450	500	550	600		
13	Clutch pedal play	○														
14	State of both brake pedals	○														
15	Operation of each lever	○														
16	Free play of steering wheel	○														
17	Toe-in							○						○		
18	Grease in front wheel hub							○								
19	Check the steering wheel joint							○						○		
20	Wheel nut fastening torque	○														
21	Operation of the instrument	○														
22	Adjustment of the throttle pedal							○								
23	Grease each nipple		○	○	○	○	○	○	○	○	○	○	○	○		
24	Oil of the 4WD front axle		★					○					●		●	
25	Check the electric wiring	○						○								
26	Hydraulic hoses & pipes							○								

### 3. TIRE SIZE AND INFLATION PRESSURE

Class	Division	Size	Air pressure (PSI)	Model
Tire (Standard)	Front	11.2-24	34 PSI	RK74PSC
	Rear	16.9-30	23 PSI	



## 4. FILLING DIAGRAM & CAPACITY TABLE

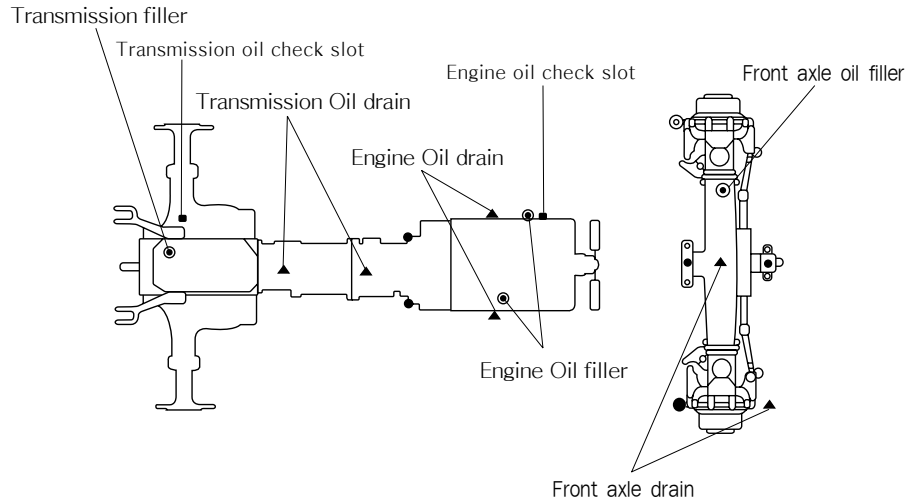

- ⊙ Oil filler hole
- Greasing point
- ▲ Drains
- Window

## 5. LUBRICANTS

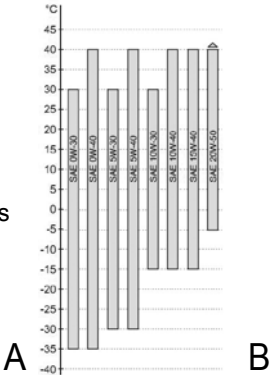
No.	Filling point	Fillings	Quantity Liter (gal.)
1	Radiator	DQC CA-14, DQC CB-14, DQC CC-14(Fresh clean Water)	2.64 US gal(10L)
2	Engine	<ul style="list-style-type: none"> <li>Deutz quality class DQCIII LA DQCIV LA</li> <li>API: CJ-4 grade</li> <li>Recommended SAE viscosity grades</li> <li>A: Viscosity</li> <li>B: Temperature</li> </ul> <div style="text-align: center; margin-top: 10px;">  </div>	8L
3	Transmission Case	(API GL-4 Grade) Tractor transmission and hydraulic oil Below -4°F(-20°C) ISO VG32 Above -4°F(-20°C) between ISO VG46 and 68	11.1 US gal (42L)
4	Front Axle	SAE 80W/90 API GL-4 Grade	4.33 US gal (16.4L)
5	Final Drive Case (B)	SAE 80W/90 API GL-4 Grade	
6	Clutch Pedal Shaft	Grease	As required
7	Ball Joint	Grease	As required
8	Fuel Tank	Diesel fuel	18.48 US gal (70L)

※ Recommended Transmission oil

1. RPM tractor Hydraulic Fluid or Textron TDH Premium (CALTEX)
2. TDH Oil or TDH Oil special (TEXACO)
3. Chevron 1000THF (CHEVRON)



## 6. OPENING METHOD OF EACH COVER

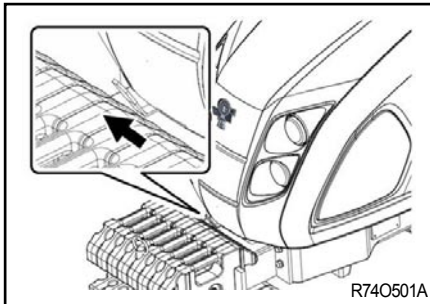

### ► FUEL

Use clean diesel fuel only.

### ⚠ IMPORTANT

- As diesel fuel equipment is susceptible to contamination by dust or water, Ensure that all dust and water is kept well away from the fuel tank.

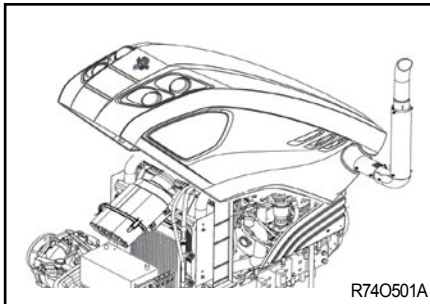

### ► OPENING METHOD OF HOOD

With the hood up, the Hook release lever can be removed by pulling left.

## 7. BLEEDING THE FUEL SYSTEM

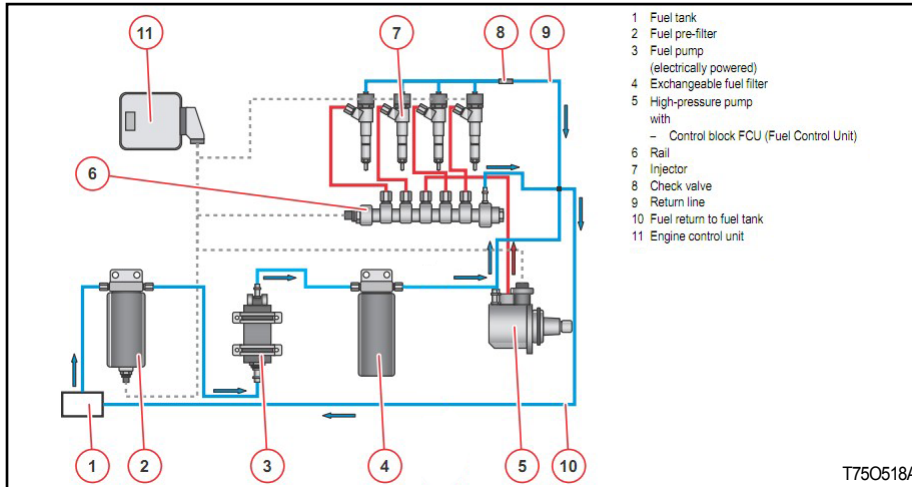





## 8. CHANGING THE OILS IN THE TRACTOR

Always use quality oils as engine or transmission oil (Refer to the page 5-9).

Refer to the table on page 5-7, 5-8, 5-9 and 5-10 for the change frequency.

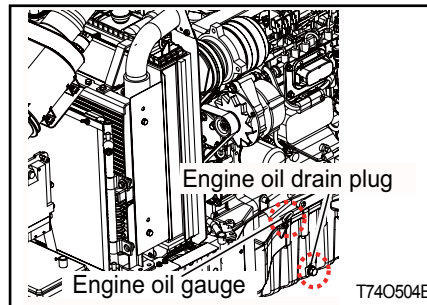
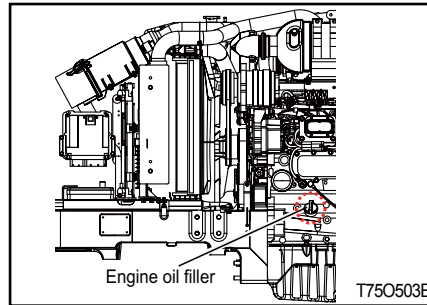

Replace and check the sump plug and refill the engine with oil to the correct level on the dipstick. (Approx. 2.11 gal)

### IMPORTANT

- When changing the oil always change the filter.
- Always use the same oil, as using different oils or specifications can cause damage.
- Dispose off the old oil as per local regulations.

### ► CHANGING ENGINE OIL

Park tractor on level surface, shut-off engine.

Remove sump plug & drain oil.

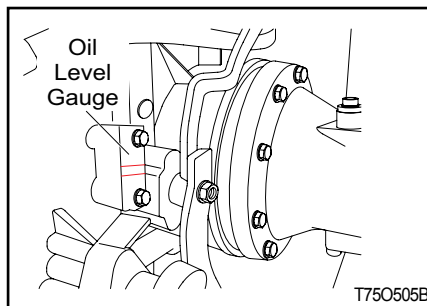
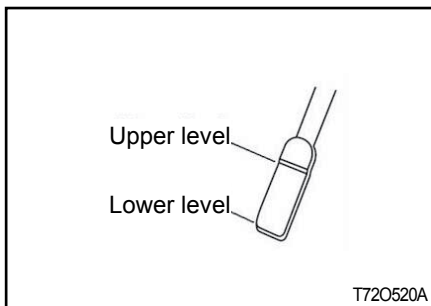
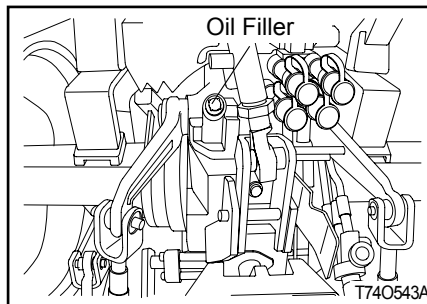
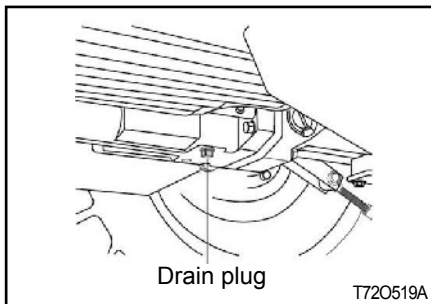

**IMPORTANT**

- Always use the same grade and specified oil as replacements.
- Dispose off the old oil as per local regulations.

**► CHANGING THE TRANSMISSION OIL**

Remove the drain plug from bottom of the transmission and drain the oil.

Replace and check the drain plug.

Refill the transmission to the correct level on the dipstick with new oil.

- Capacity: 18 US gal (68L)

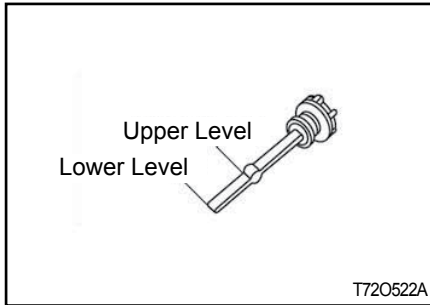

## ► CHANGING OIL IN THE FRONT AXLE

Refill the transmission to the correct level on the dipstick with new oil.

- Capacity: 4.3 US gal (16.4L)

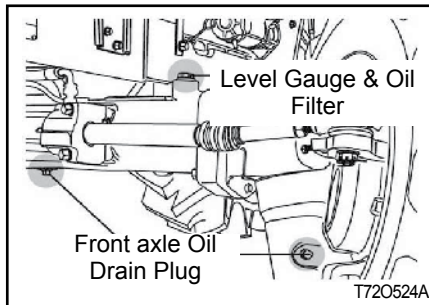
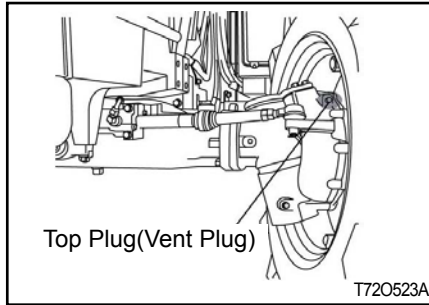

### IMPORTANT

- Some operators have found that when they fill with the correct amount of oil and dip it, the oil level on the dipstick is too high due to the fact that it takes a while for the oil to run into the final drives.
- Opening the Vent plugs helps to speed this up.



## 9. CLEANING AND CHANGING FILTERS

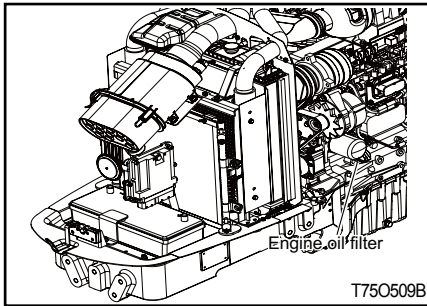

### ► ENGINE OIL FILTER

Using a filter wrench turn the filter anti clockwise to remove it. Lightly smear the rubber seal on the new filter with oil to ensure, turn it clockwise until the seal contacts the base and then turn it another 2/3 turn to tighten it.

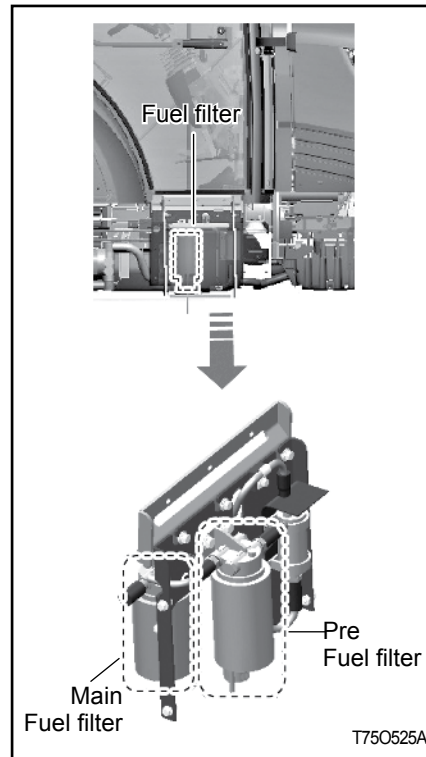

### ► CLEANING OIL WATER SEPARATOR OF FUEL FILTER

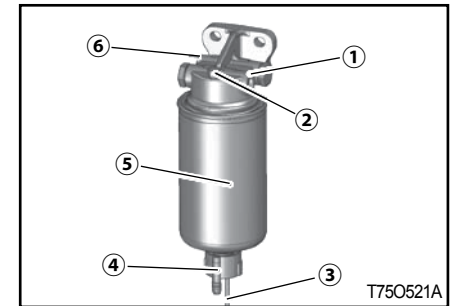

### ► CHANGE/VENT FUEL PRE-FILTER

1. Fuel supply flow to the pump
2. Venting screw
3. Electrical connection for water level sensor
4. Drain plug
5. Filter insert
6. Fuel inlet from the fuel tank



### ► EMPTY WATER TANK

- Switch off the engine.
- Place suitable collecting containers underneath.
- Electrical connection
  - Disconnect cable connections.
- Loosen drain plug.
- Drain fluid until pure diesel fuel runs out.
- Mount drain plug.  
Tightening torque  $1.6 \pm 0.3$  Nm
- Electrical connection
  - Connect cable connections.

### ► CHANGE THE FUEL PRE-FILTER INSERT

- Switch off the engine.
- Shut off the fuel supply to the engine (with highlevel tank).
- Place suitable collecting containers underneath.
- Electrical connection
  - Disconnect cable connections.
- Loosen drain plug and drain liquid.
- Disassemble filter insert.
- Clean any dirt off the sealing surfaces of the new filter cartridge and opposite side of filter head.
- Wet the sealing surfaces of the filter cartridge slightly with fuel and screw back on to the filter head, clockwise (17-18 Nm).
- Mount drain plug.  
Tightening torque  $1.6 \pm 0.3$  Nm
- Electrical connection
  - Connect cable connections.
- Open the fuel shutoff tap and vent the system, see venting the fuel system.

### ► VENT THE FUEL SYSTEM

The fuel system is vented via the electric fuel supply pump.

In order to ensure that no error messages are generated, no attempt should be made to start the system up whilst venting.

This process is carried out as follows:

- Ignition "ON"  
The electronic fuel supply pump switches on for 20 seconds in order to vent the fuel system and build up the required fuel pressure. Wait until the electric fuel supply pump is disconnected from the control unit.
- Ignition "OFF"  
Repeat the process at least 2 times until the fuel system is vented.

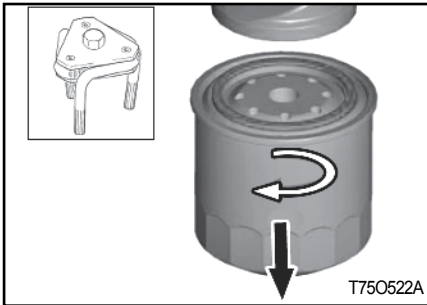

- Remove clamps when twist protection mounted (optional).
- Loosen and unscrew filter with tool (order no.: 0189 9142)
- Catch any escaping fuel.
- Clean the sealing surface of the filter support with a lint-free, clean cloth.

► **CHANGE THE FUEL FILTER CARTRIDGE**

**⚠ DANGER**

The filter cartridge should never be prefilled. There is a danger of dirt contamination!

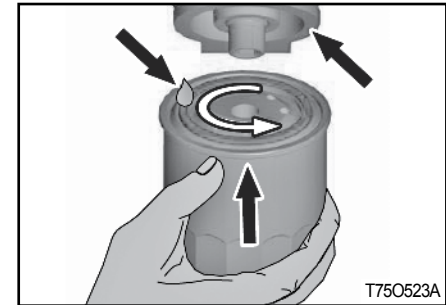

- Oil the gasket of the new DEUTZ original filter cartridge lightly.
- Screw on new filter by hand until the gasket is touching and tighten with a torque of: 10-12 Nm
- Fasten clamps of the twist protection (optional).
- Vent the fuel system

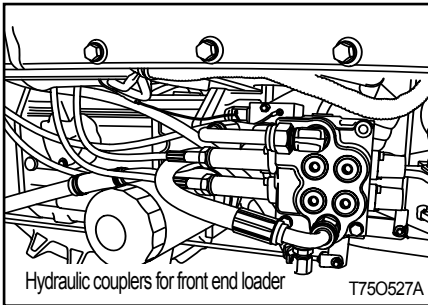

## ► HYDRAULIC OIL FILTER AND ENGINE OIL FILTER CARTRIDGE

Remove the filter with a filter wrench.

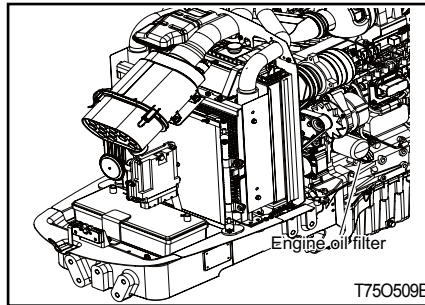

To replace, apply oil or grease on the seal, fit by hand until seal contacts bare, then turn it 2/3rd turn further to tighten it check for leaks.

## 10. CHANGING THE COOLANT

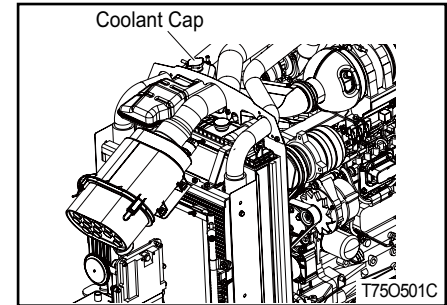

1. Open the drain cock in front of the engine oil filter to drain the coolant.

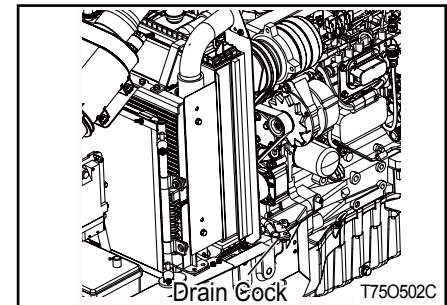

2. Open the Coolant cap at the same time.



3. To give a thorough clean run a hose into the radiator and flush it out.
4. Close the drain cock and refill the radiator with a coolant mixture of water and corrosion inhibitor or anti freeze.
5. Start the engine and allow it to run for approx 5 minutes, check the water level again and top up if required.

**CAUTION**

- Do not remove the radiator cap on a hot engine.
- Allow the engine to cool down and then turn the cap slowly to ensure, that there is no excessive pressure in the radiator.

**CAUTION**

- Serious burns, can result from the contents of pressurized, hot radiators.
- Allow the engine to cool down completely before opening radiator cap.

**► ANTI FREEZE**

Frozen cooling water can damage the engine.

Before replacing the anti freeze solution flush the radiator.

Mix the anti freeze solution in accordance with the instructions applicable to the brand of anti freeze and the locals climate.

Replace the solution in the radiator.

In case of loss of solution due to evaporation or overflow, replace with the original mixture ratio.





## 11. GREASING THE TRACTOR

Grease the tractor according to the service schedule. (Page 5-10)

Ensure that grease nipples are cleaned well before any attempt is made to grease them.

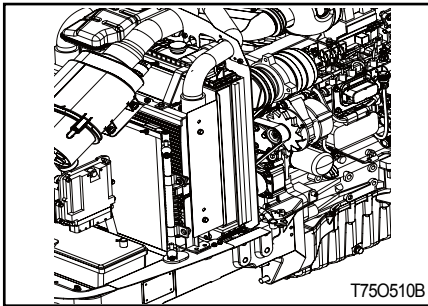

### ► CLEANING THE RADIATOR

Insects, grass straw and dust can all block the radiator, condenser and reduce its efficiency. Remove the radiator cover to clean it and the radiator. Release the bolt and pull to remove the cover. Then clean the radiator between the fins and tube by using clean water.

### ⚠ IMPORTANT

- Water or air under high pressure can distort the cooling fins on the radiator and reduce its efficiency.

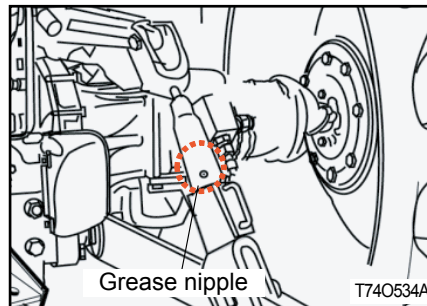
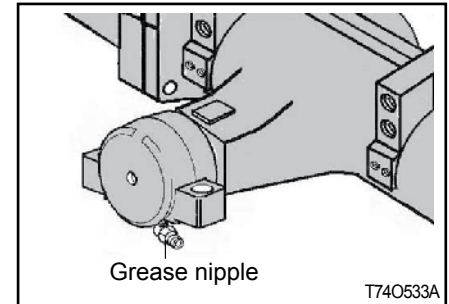
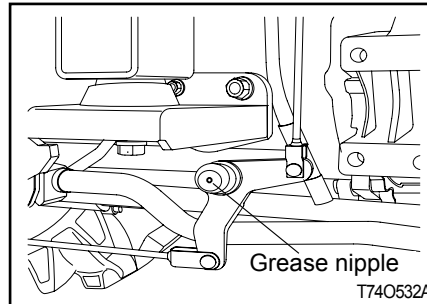



**12. GAP ADJUSTMENT**

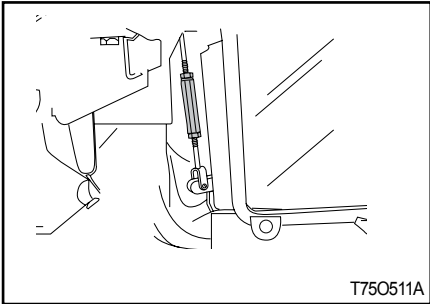

**► ADJUSTING THE CLUTCH**

Using the clutch over a period of time will increase the free play.

The correct free play of the pedal is 0.78~1.18 in. (20~30mm).

To adjust, loosen the locknut on the turnbuckle and adjust.

Check the adjustment and tighten the locknut if the free play is correct.

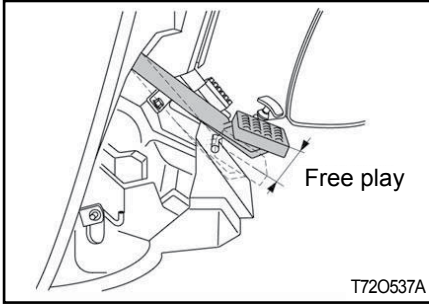

**► ADJUSTING THE BRAKES**

As is the case with the clutch, use of the brakes will change the pedal free play and the balance between the right and left pedal.

The correct pedal free play is 1.18~1.57 in. (30~40mm).

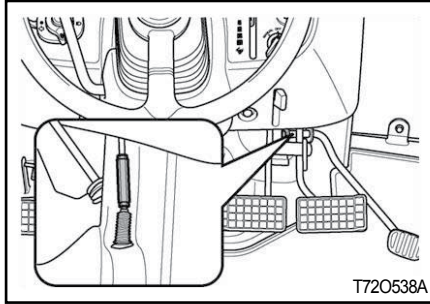

**► ADJUSTMENT METHOD**

Loosen the double locknuts to adjust the brake.

Turning it to increases the free play, or decreases it.

Tighten the double locknuts and confirm to fix the Nuts.

Check that the free play is correct and the same on both pedals to ensure even braking.



**CAUTION**

- Uneven adjustment of the left and right pedal will result in one sided braking when the pedals are connected and can cause serious accidents, especially at high speeds.
- Double check to ensure free play is the same on both pedals.

**► ADJUSTING THE THROTTLE LEVE**

If this lever is either loose or difficult to move please consult your dealer for rectification of the problem.

**► ADJUSTING TOE-IN**

If the toe-in adjustment is incorrect it can cause severe shaking of both the steering wheel and the entire tractor.

The correct toe in is 0.08~0.24in. (2~6mm) We recommend that this adjustment is made by the dealer.



## 13. BATTERY MAINTENANCE

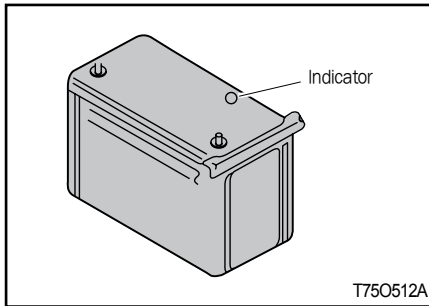

### ► CHECKING THE BATTERY

To the battery there is an inspection charging indicator.

- ● GREEN: Good condition
- ● BLACK: Charging necessary
- ○ WHITE: Replace battery

### ⚠ CAUTION

- Electrolyte contains acid and can cause serious burns.
- Any spillage on skin should be washed off by running water immediately.

### ► BATTERY MAINTENANCE

Low temperatures will affect the performance of batteries so take particular care of it in winter.

For long-term storage of the tractor remove the battery and keep it in a cool dry room.

If it is on the tractor while stored, disconnect the negative terminal.

Batteries will self discharge if left for a period of without use time.

To keep them in good condition charge them once a month in summer and every second month in winter.

When replacing the original battery, ensure that the replacement battery is the same size.

Failure to do so can cause problems with the electrical circuit.

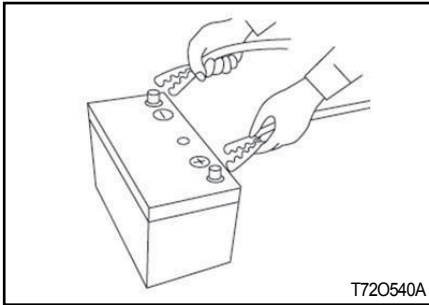

### ► BATTERY CHARGING

A boost charge is only for emergencies. It will partially charge the battery at a high rate and in a short time.

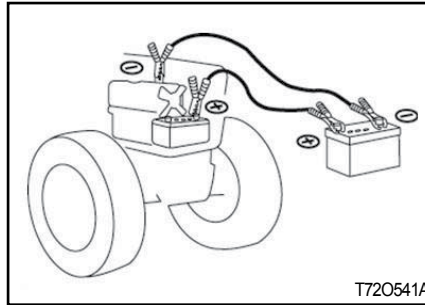

When using a boost-charged battery, it is necessary to recharge the battery as early as possible.

Failure to do this will shorten the battery's service life.

### ⚠ CAUTION

- Always disconnect the negative terminal first when removing the battery and always connect the positive terminal first when fitting the battery.
- When connecting the battery leads make sure not to reverse the polarity.
- Quick charging will reduce battery life.
- Disconnect the terminals prior to charging the battery to avoid damage to the circuit and electrical instruments.



## 14. OTHER MAINTENANCE

### ► CHECKING THE BELT DRIVE

#### ⚠ CAUTION

- Only carry out work on the belt drive with the engine at a standstill !
- After repair work: Check that all guards have been replaced and that all tools have been removed from the engine.

- Check the whole belt drive visually for damage.
- Renew damaged parts.
- Remount protective devices if necessary.
- pay attention to correct fit of new belts, check the tension after running for 15 minutes.

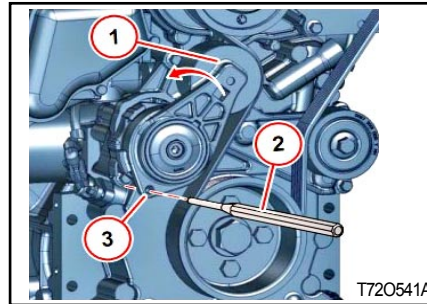

### ► REPLACE V-RIB BELT

1. Tension pulley
2. Retaining pin
3. Assembly bore

- Press tensioning roller with socket wrench in the direction of the arrow until a retaining pin can be fixed in the assembly bore. The V-ribbed belt is now tension free.
- First pull the V-ribbed belt off the smallest roller or off the tensioning roller.

- Mount new V-ribbed belt.
- Retain tensioning pulley using the pin wrench and remove the holding pin.
- Tension V-ribbed belt using the tensioning roller and socket wrench. Check whether the V-ribbed belt is correctly in its guide.

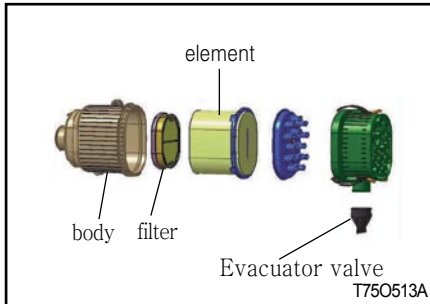

### ► CHECK AND CLEAN THE AIR CLEANER ACCORDING TO THE FOLLOWING INSTRUCTIONS

- Filter part number: 10031032020
- Element part number: 10031032050

### < Cautions for inspection and service of air cleaner >

- (1) Use the standard element and filter and do not apply oil on them.
- (2) Remove any dust in the cover thoroughly.

- (3) Install it firmly so that dust does not enter below the cover.
- (4) Never drive with the element and filter removed.
- (5) Replace the air cleaner filter and element according to their replacement schedule and when their indicator comes on.

#### NOTE

- Do not hit the element with a rock or concrete during its cleaning.
- Make sure to install the element firmly.
- Tighten each part of the air cleaner securely to block dust completely.

Replace the element after cleaning it 5 times or it is damaged.

### ► CHECKING HOSES AND LINES

The fuel lines, radiator hoses, hydraulic and rubber hoses are consumables, which deteriorate by age and use.

Check them regularly and replace if faulty.

#### CAUTION

- Damaged fuel lines leak and cause fires.
- Damaged radiator hoses can cause hot water burns and in severe cases seize the engine.



► **CHECKING THE WIRING HARNESS AND FUSES**

Loose wires make inferior connections and damaged wires can cause short circuits, fires burnt wiring or reduce efficiency of components.

Replace or repair any faulty wiring or insulation.

If a fuse burns out again after it has been replaced, do not replace it with wire or a high capacity fuse, find the cause and rectify it or get an auto electrician to do so.

Where insulation is chafed or peeled off, recover the area with a good quality insulation tape. Where wiring comes out of it's fitting replace it correctly with the standard fitting.

**IMPORTANT**

- Incorrect wiring or fuses can cause fires to both the tractor and surrounding area so get the dealer to check it annually.
- Likewise fuel pipes and wiring age with use.
- Ask your dealer to check it at least once every 2 years and replace as required.

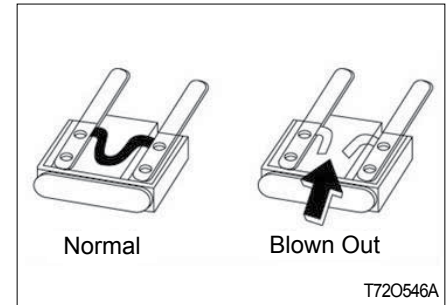

► **REPLACING FUSES**

The circuit has 8 blade type fuses in its wiring circuit. (See diagram on page 9-2 and 9-3)

When a fuse has blown replace it with one of the same value.

Using a large capacity fuse or wire burn out the wiring system.

Use fuse tongs to replace fuses.



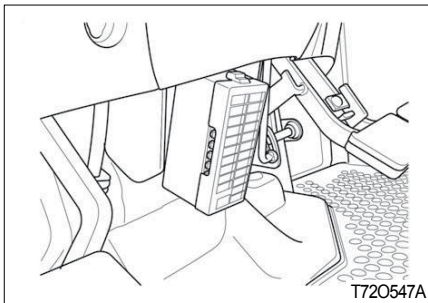

### ► MAIN FUSES

The wiring harness is equipped with 3 main fuses whose function is to preserve the wiring.

However when a main fuse blows the entire circuit is dead.

Always check the reason & rectify before replacing the fuse of the same value.

To indicate that the fuse is blown it will be discolored.

### ⚠ IMPORTANT

- Always check the reason for a blown fuse otherwise the new fuse is also likely to blow.  
Never ever use wire in place of correct grade fuse.

## 15. STORAGE

### ► SERVICE PRIOR TO DAILY AND SHORT TERMS STORAGE

Wash the tractor and keep it clean.

Fill the tank to avoid condensation and rust.

Lower any attached implement to the ground before parking the tractor.

For long-term storage consult your dealer.



## ► FOR DAILY OR SHORT TERM STORAGE

Clean the tractor and remove all dirt from field work.

Fill the fuel tank to avoid condensation and rust.

Lower the implement to the ground.

Keep it in a machinery shed or, if not available cover the unit if left outside.

In very cold conditions it is advisable to remove the battery and keep it inside in a warm environment.

This will ensure effective starting when the tractor is required.

When the outside temperature is below 32°F (0°C), replace the Anti-freeze completely or drain the coolant to protect the engine from damage from frozen coolant.

### IMPORTANT

- When washing the tractor ensure that the water does not get near electrical components or the oil filter points.
- To prevent short circuits remove the ignition key.
- Do not wash the tractor when the engine is running.

## ► LONG-TERM STORAGE

When the tractor will not be used for a long time carry out the cleaning as for short term storage.

Drain the oil and replace with new oil.

Run the engine for approx. 5 min. to ensure that it has new oil throughout the engine.

Drain the coolant from the radiator and remove the ignition key.

Attach a tag both the key and the steering wheel saying "No coolant".

Lubricate all grease and oil points on the tractor.

Check the pressures and add a small amount of extra pressure.

Lower any implement to the ground or store in a shady dry place.

Disconnect the clutch by using the clutch disconnecting arm.

Place a piece of wood under each tire to preserve the tire.



### **+** IMPORTANT

- After refilling the engine with the coolant run the engine for approx. 5~10 min. at 1,500~2,000 rpm every month as a corrosion prevention measure.
- Either removes the battery or the negative terminal as mouse damage to wiring can cause short circuits and fires.
- Remove the ignition key and store in a safe place.

### **▶ RE-USE AFTER LONG TERM STORAGE**

Carry out a full check of all oils and coolant.

Refit the battery and run the engine at idle for 30 min. to ensure optimum engine life.

## 16. FUEL SAVING TIPS

To save fuel & oil in your tractor, following things should always be kept in mind.



► **AIR CLEANING SYSTEM**

1. Clean the air cleaner regularly so that dust does not settle down.
2. For every 50 hours & everyday in sandy/dusty conditions.
  - Clean the air cleaner filter element with compressed air.
  - If the rubber ring is cut or expanded then change it with an appropriate one. Fix the rubber at the proper location & check for leakages if any.
  - If air is leaking through the hose connection, check & rectify other leakages, too.

**NOTE**

- If air cleaning system is not properly maintained, it will lead to early wear of piston rings & sleeves. This will lead to problems like loss of engine power, excessive oil consumption fuel consumption.

► **ENGINE**

1. Put the engine oil on load after the engine is heated & the water temperature gauge indicates the needle to be in the green zone.
2. If excessive black smoke is visible, then the paper element of air cleaner, Fuel injection pump or nozzles should be checked.
3. Do not run the engine without load for more than 2 minutes. It is better to stop the engine rather than run it idle. This will help in saving of fuel.

► **CLUTCH & BRAKES**

1. Do not reduce the power of the power of the engine by depressing the clutch halfway. Instead use low gear.
2. If the tractor has to be stopped for a long period, it is advisable to bring the transmission in neutral position & release the clutch pedal.
3. Do not over ride the clutch & brake pedals.
4. While coming down from a slope, reduce the engine throttle & use low gear. Do not depend only on the brakes for stoppage.



### ► OIL SYSTEM

1. Always use recommended grade of oil.
2. Everyday before starting the engine, check the oil level with a dipstick & refill between the minimum & maximum level.
3. Charge the engine oil. Replace filter & "O" ring, as & when required.

### ► LUBRICATING OIL

#### GENERAL

Modern diesel engines place very high demands on the lubricating oil to be used. The specific engine performances which have increased constantly over the last few years lead to an increased thermal load on the lubricating oil. The lubricating oil is also more exposed to contamination due to reduced oil consumption and longer oil change intervals. For this reason it is necessary to observe the requirements and recommendations described in this operating manual in order not to shorten the life of the engine.

Lubricating oils always consist of a base oil and an additive package. The most important tasks of a lubricating oil (e.g. wear protection, corrosion protection, neutralisation of acids from combustion products, prevention of coke and soot de-

posits on the engine parts) are assumed by the additives. The properties of the base oil are also decisive for the quality of the product, e.g. with regard to thermal load capacity.

In principle, all engine oils of the same specification can be mixed. However, mixing of engine oils should be avoided because the worst properties of the mixture are always dominant.

The lubricating oils approved by DEUTZ have been thoroughly tested for all engine applications. The active ingredients they contain are compatible with each other. Therefore, the use of additives for lubricating oils is not permitted in DEUTZ engines.

The **lubricating oil quality** has a considerable influence on the life, performance and thus also on the costs-effectiveness of the engine. It basically applies that: The better the lubricating oil quality, the better these properties.



The lubricating oil viscosity describes the way the lubricating oil flows, depending on the temperature.

The **lubricating oil viscosity** only has a small influence and effect on the quality of the oil.

**Synthetic lubricating oils** are used increasingly and offer advantages. These lubricating oils have better temperature and oxidation stability as well as relatively low cold viscosity. Since some processes which are relevant for determining the lubricating oil change times are largely dependent on the oil quality (e.g. the infiltration of soot and other contamination), the oil change time for synthetic lubricating oils may not be increased in relation to the specifications on lubricating oil change intervals.

**Biodegradable lubricating oils** may be used in DEUTZ engines if they meet the requirements of this operating manual.

### QUALITY

Lubricating oils are classified by DEUTZ according to their performance and quality class (DQC: DEUTZ Quality Class). Essentially, the following applies: the higher the quality class (DQC I, II, III, IV), the more effective/the better quality the lubricating oil is.

The DQC quality classes are still to be extended by the DQC-LA quality classes which include the modern, low-ash lubricating oils (LA = Low Ash).

Lubricating oils according to other comparable specifications can be used as long as they meet DEUTZ requirements. In regions in which none of these qualities are available, please contact your responsible DEUTZ partner.

or see [www.deutz.com](http://www.deutz.com)

<a href="http://www.deutz.com">http://www.deutz.com</a>	
de	\\SERVICE \Betriebsstoffe und Additive \Deutz Quality Class\DQC-Freigabeliste
en	\\SERVICE \Operating Liquids and Additives \Deutz Quality Class \DQC Release List

The choice of lubricating oil essentially depends on the exhaust after-treatment system.

The following lubricating oils are permissible for the engines in this operating manual:



PERMISSIBLE QUALITY CLASS	
DEUTZ	Others
<b>Engines with exhaust aftertreatment system</b>	
DQC III LA *	Please contact your DEUTZ partner
DQC IV LA *	
<b>Engines without exhaust aftertreatment system</b>	
DQC II	Please contact your DEUTZ partner
DQC III	
DQC III LA *	
DQC IV	
DQC IV LA *	

\* Sulphur content in the fuel < 15 mg/kg

For low-ash engine oils released according to the DQC system an appropriate reference is made in the oil release list.

DEUTZ lubricating oils DQC III LA low-ash DEUTZ Oil Rodon 10W40 Low SAPS	
Container	Order number:
20 litre canister	0101 7976
209 litre barrel	0101 7977

DEUTZ lubricating oils DQC II TLS - 15W40 D	
Not for engines with exhaust gas aftertreatment	
Container	Order number:
5 litre container	0101 6331
20 litre canister	0101 6332
209 litre barrel	0101 6333

DEUTZ lubricating oils DQC III TLX - 10W40 FE	
Not for engines with exhaust gas aftertreatment	
Container	Order number:
5 litre container	0101 6335
20 litre canister	0101 6336
209 litre barrel	0101 6337

DEUTZ lubricating oils DQC IV synthetic DQC IV - 5W30-UHP	
Not for engines with exhaust gas aftertreatment	
Container	Order number:
20 litre canister	0101 7849
209 litre barrel	0101 7850



## ► LUBRICATING OIL CHANGE INTERVALS

- The intervals depend on:
  - lubricating oil quality
  - sulphur content in the fuel
  - type of application of engine
  - Number of standstill regenerations
- The lubricating oil change interval must be halved if at least one of the following conditions applies:
  - Constant ambient temperature below  $-10\text{ °C}$  ( $14\text{ °F}$ ) or lube oil temperature below  $60\text{ °C}$  ( $84\text{ °F}$ ).
  - Sulphur content in diesel fuel of  $>0.5\text{ weight \%}$ .
  - If the lubricating oil change intervals are not reached within a year, the oil should be changed at least once a year.

## VISCOSITY

The ambient temperature at the installation site or in the application area of the engine is decisive for choosing the right viscosity class. Too high a viscosity can lead to starting difficulties, too low a viscosity can endanger the lubrication effect and cause a high lubricating oil consumption. At ambient temperatures below  $-40\text{ °C}$ , the lubricating oil must be pre-heated (e.g. by storing the vehicle or the machine in a hall).

The viscosity is classified according to SAE. Multipurpose lubricating oils should be used basically.

Single-purpose lubricating oils can also be used in enclosed, heated spaces at temperatures  $>5\text{ °C}$ .

### NOTE

- The prescribed lubricating oil quality must be observed when selecting the viscosity class!

Depending on the ambient temperature we recommend the following common viscosity classes:



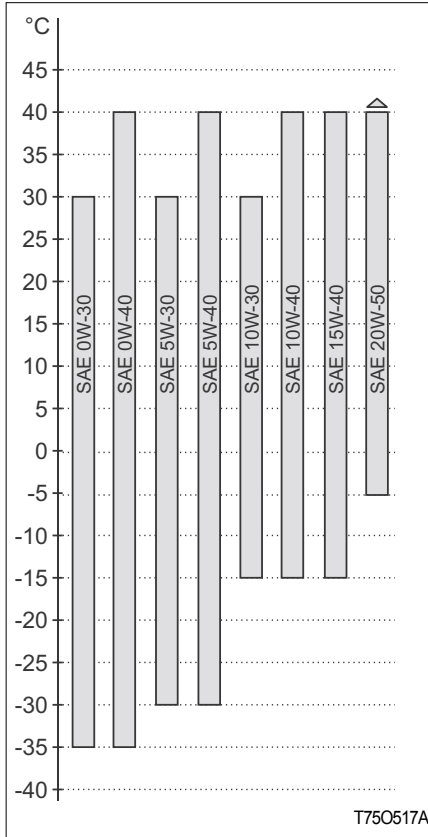

## ► FUEL SYSTEM

1. Always use filtered diesel for the fuel system.
2. At the end of the day's working, it is preferable to fill the diesel tank so that it may prevent condensation.
3. Change the filter, if the system gets choked. Do not change both the filters at the same time. If the above directives are not adhered to, the fuel injection pump & injection nozzle will lose its life early. Also, it will lead to excessive black smoke & excessive diesel consumption.

## ► FUEL

### PERMISSIBLE FUELS

In order to satisfy the exhaust gas legislation, diesel engines that are equipped with an exhaust aftertreatment system may only be operated with a sulphurfree diesel fuel.

#### Exhaust aftertreatment systems

DOC	Diesel oxidation catalytic converter
DOC / DPF	Diesel oxidation catalytic converter Diesel particle filter

The operational reliability and durability of the individual exhaust aftertreatment technologies cannot be assured upon failure to comply. The following fuel specifications / standards are approved:

- Diesel fuels
    - EN 590
- Sulphur <10 mg/kg
- ASTM D 975 Grade 1-D S15
  - ASTM D 975 Grade 2-D S15

- Sulphur <15 mg/kg
- Light heating oils
    - in EN 590 quality

Sulphur <10 mg/kg

**Exhaust aftertreatment systems**

without

The following fuel specifications / standards are approved:

- Diesel fuels
- in EN 590 quality
- Sulphur <2,000 mg/kg
- ASTM D 975 Grade 1-D S15
- Quality
- ASTM D 975 Grade 2-D S15

Quality

Sulphur <2,000 mg/kg

Light heating oils

- in EN 590 quality

Sulphur <2,000 mg/kg

If other fuels are used which do not meet the requirements of the operating manual, the warranty will be voided.

The certification measurements for compliance with the legal emission values are made with the test fuels specified in the laws. These correspond to the diesel fuels in accordance with EN 590 and ASTM D 975 described in the operation manual. No emission values are guaranteed with the other fuels described in this operation manual.

The respective fuels prescribed by law must be used to comply with the national emission regulations (e.g. sulphur content).

Please contact your DEUTZ partner or see [www.deutz.com](http://www.deutz.com)

<a href="http://www.deutz.com">http://www.deutz.com</a>	
de	\\SERVICE\Betriebsstoffe und Additive\ <b>Kraftstoffe</b>
en	\\SERVICE\Operating Liquids and Additives\ <b>Fuels</b>



### WINTER OPERATION WITH DIESEL FUEL

Special demands are placed on the cold behaviour (temperature limit value of the filtrability) for winter operation. Suitable fuels are available at filling stations in winter.

#### IMPORTANT

- For engines with common rail injection, the mixing of petroleum and adding of extra low additives is not permissible.

At low ambient temperatures paraffin discharges can lead to blockages in the fuel system and cause operating faults. Below 0 °C ambient temperature use winter diesel (down to -20 °C) (filling stations provide this in good time before the cold season starts).

- Special diesel fuels can be used for arctic climates to -44 °C.

### ► COOLING SYSTEM

1. Check the fan belt tension regularly. Adjust, if required.
2. Check the coolant level in the radiator fins always clean.
3. Replace the radiator cap with a genuine cap only, if required.
4. Do not remove the thermostat but replace with a new one, if required.
5. Do not change the radiator water often.

### ► GENERAL

#### CAUTION

- Never operate the engine without coolant, even for a short time!

In liquid-cooled engines, the coolant must be conditioned and monitored, otherwise the engine could be damaged by:

- Corrosion
- Cavitation
- Freezing
- Overheating



## WATER QUALITY

The right water quality is important for conditioning the coolant. Clear, clean water within the following analysis values should always be used:

Analysis values		Min	Max	ASTM
ph value		6.5	8.5	D 1293
Chlorine (Cl)	[mg/l]	-	100	D512 D4327
Sulphate (SO4)	[mg/l]	-	100	D 516
Total hardness (CaCO3)	[mmol/l] [mg/l]		3.56 356	D 1126
	[°dGH]		20.0	-
	[°e]		25.0	
	[°fH]		35.6	

Specifications of the water quality are made by the local water board.

The water must be conditioned if it deviates from the analysis values.

- **pH value too low:**

Addition of diluted sodium or potassium lye.

Small trial mixtures are advisable.

- **Total hardness too high:**

Mixing with softened water (pH neutralized condensate or water softened by ion exchanger).

- **Chlorides and/or sulphates too high:**

Mixing with softened water (pH neutralized condensate or water softened by ion exchanger).

## COOLING SYSTEM CORROSION PROTECTION AGENT

**CAUTION**

- Health damaging nitrous amines form when nitrite-based cooling system corrosion protection agents are mixed with amine-based agents!

**NOTE**

- Cooling system corrosion protection agents must be disposed of in an environmentally friendly way.
- Observe the notes on the safety datasheet.



The conditioning of the coolant for liquid-cooled

DEUTZ compact engines is performed by mixing an

anti-freeze with corrosion protection inhibitors based

on ethylene glycol into the water.

DEUTZ cooling system corrosion protection agent	
Container	Order number:
5 litre container	0101 1490
20 litre canister	0101 6416
210 litre barrel	1221 1500

This cooling system corrosion protection agent is free from nitrite, amine and phosphate and is adapted to the materials in our engines. Order from your DEUTZ partner.

Please contact your DEUTZ partner if the DEUTZ cooling system corrosion protection agent is not available.

or see [www.deutz.com](http://www.deutz.com)

<a href="http://www.deutz.com">http://www.deutz.com</a>	
de	\SERVICE\Betriebsstoffe und Additive\Kühlsystemsenschutz
en	\SERVICE\Operating Liquids and Additives\Cooling System Conditioner

The cooling system must be monitored regularly.

This also includes checking the coolant system corrosion protection agent concentration in addition to checking the coolant level.

The cooling system corrosion protection agent concentration can be checked with conventional test instruments (e.g. refractometer).w

Cooling system corrosion protection agent percentage	Water percentage	Cold protection up to
min. 35 %	65 %	-22 °C
40 %	60 %	-28 °C
45 %	55 %	-35 °C
min. 50 %	50 %	-41 °C

At temperatures below -41 °C, please contact your responsible DEUTZ partner.

It is possible to use other cooling system corrosion protection agents (e.g. chemical corrosion protection agents) in exceptional cases. Consult your DEUTZ partner.



## **CABIN SYSTEM**

<b>1. MAJOR FEATURES .....</b>	<b>6-2</b>
<b>2. INSTRUMENT AND RELATED PARTS.....</b>	<b>6-3</b>
<b>3. HOW TO CONTROLS CABIN .....</b>	<b>6-5</b>



## 1. MAJOR FEATURES

The cab fully conforms to the international standard as far as safety and soundproofing are concerned.

It can be provided with ventilation, heating and air-conditioning system.

It is available in the following version:

- Cab with ventilation and heating systems.
- Cab with ventilation, heating and air-conditioning systems.

### CAUTION

- The cab is in full conformity with the international standards as to the cab's soundproofing.
- Be very careful when operating in small spaces and always protect your ears whenever other working equipment is generating dangerous noise levels.

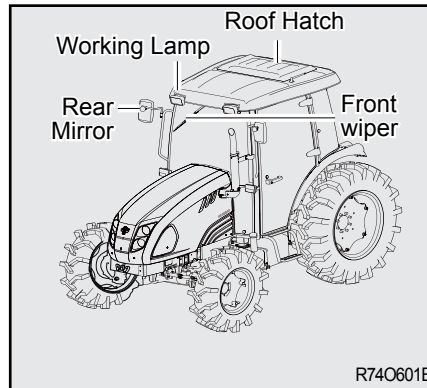
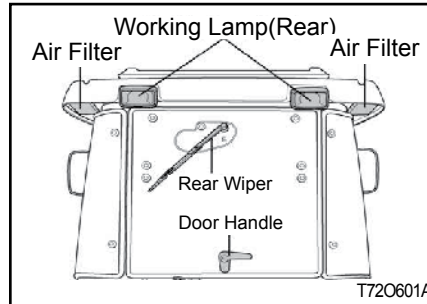

### CAUTION

- Remember that steering, braking and operational performances are highly influenced by the implements mounted, the trailers transported and the ballasts applied to the tractor

### CAUTION

- When transporting heavy loads (Exceeding the weight of the tractor) reduce the speed under 15 Km/h (9.32 m/h).

### CAUTION

- All the implements mounted onto the tractor must be safely secured.

### CAUTION

- Be very careful during implement hitching and unhitching operations. When using implement supports, be sure they are suitable and sufficiently strong.



## 2. INSTRUMENT AND RELATED PARTS

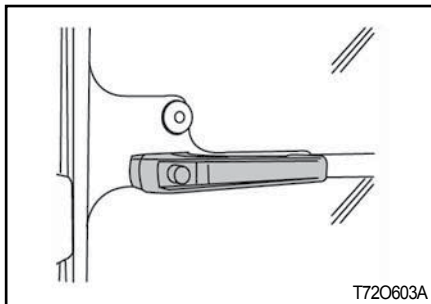

### ► DOORS

The doors are provided with key locks.

To open from the outside, when unlocked, depress the push button.

To open from inside, push the lever downwards.

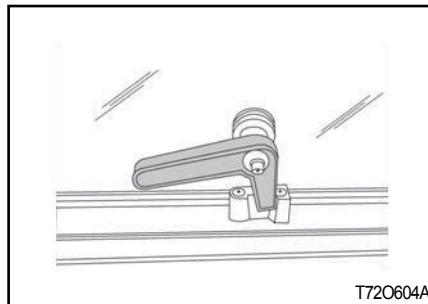

### ► REAR WINDOW

The rear window is fitted with central handle for opening.

When opened it is held in place by two dampers.

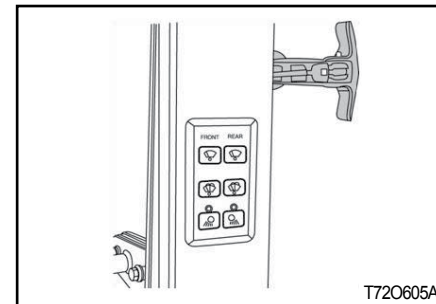

### ► SIDE WINDOW

The side window is fitted with central handle for opening.

When opened it is held in place by holder.





### ► WORKING LAMPS (FRONT AND REAR)

The working lamps are located on the cab roof (Two in the front and two in the rear). They are switched on by means of the special switches on the roof console.

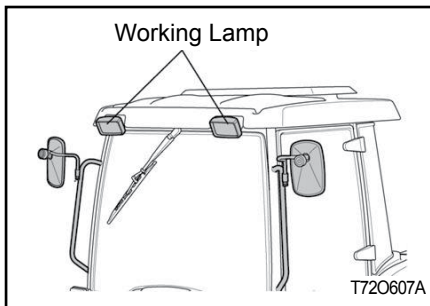
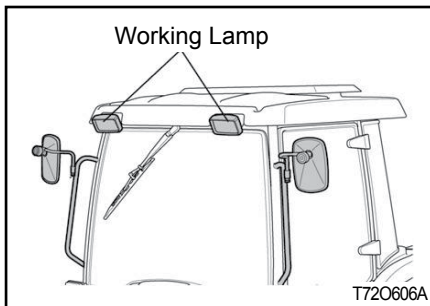

### ► REARVIEW MIRRORS

The cab is provided with rearview mirrors on both sides. They can be adjusted and folded, whenever necessary, to avoid interference with external obstacles.

The mirror have a telescopic arm to allow positioning for maximum convenience by the user.

Remember that mirrors must always be positioned in compliance with road traffic regulations when driving on a public highway.

### ► CAB CEILING

The ceiling is padded with insulation material to block heat radiation into the cab and keep the temperature down when working in very sunny areas.

The cab platform is covered with a "firm grip" carpet in the most commonly used areas.

It is recommended to keep this carpet clear of earth, mud, etc. so that the operator may get on and off the tractor in full safety.



### 3. HOW TO CONTROLS CABIN

#### ► INTERIOR DEVICES

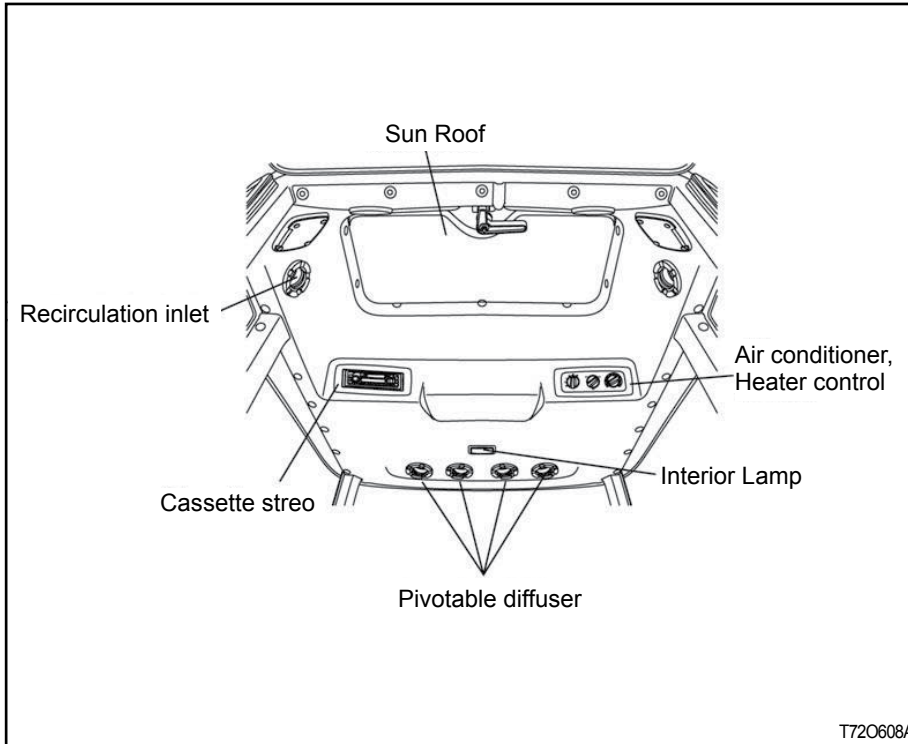

#### ► VENTILATION

The ventilation unit is housed in the cab ceiling.

To switch it on and adjust it, turn the electrical fan switch to the desired speed.

The cab becomes slightly pressurized when the ventilation system is in operation, so that the fresh air can enter only by way of the filter installed in the rear section of the cab roof.

The fan switch can be operated only after the ignition key is inserted.

The air flow can be regulated and directed by suitable positioning the air diffusers.

Air can be taken in fresh from outside or recirculated from within the cab by way of the relative side inlets.



### RECIRCULATION INLETS FULLY CLOSED

Air is taken in entirely from outside the cab through the rear grille and filtered through a paper element positioned behind the grille.

※ N.B: It is very important that the air diffusers never be completely closed so as to allow for a steady air flow.

To obtain a greater pressurization inside the cab, it is necessary to take the air from the outside, therefore the inside air recirculating grille should be fully closed.

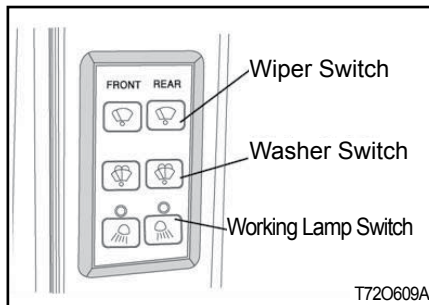

### ► WORKING LAMP SWITCH

The front and rear working lights are "ON" when push the button. The work light indicator lamp on the instrument cluster will illuminate.

### ► WIPER CONTROL SWITCH

#### < ON SWITCH >

- Wind screen wiper operation.
- Continuous pushing button operates wiper and washer pump.

#### < OFF SWITCH >

- Wind screen wiper "Off" and operates washer pump.

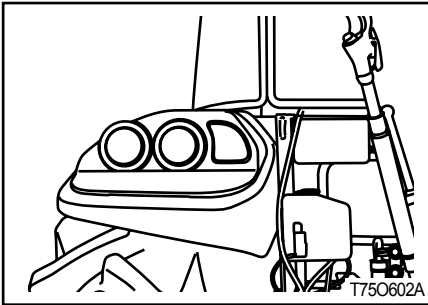

### ► WINDSCREEN WASHER TANK

Check the level of windscreen washer fluid in the plastic reservoir located on the rear side of tractor.

During winter it is advisable to add a suitable antifreeze or methyl alcohol to the windscreen washer fluid.

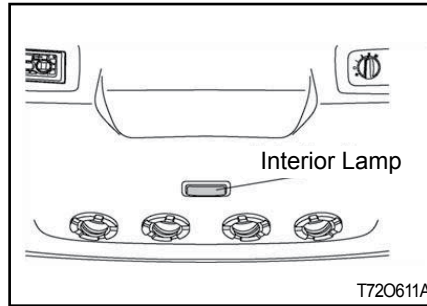

### ► INTERIOR LAMP

Push the button to light on and push it again to light off.

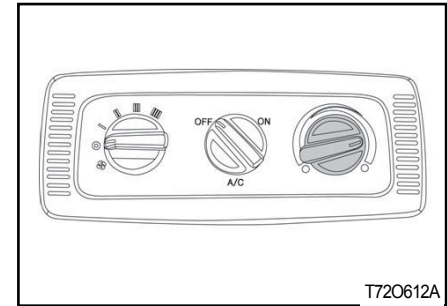

### ► BLOWER CONTROL SWITCH

Three position rocker switch.

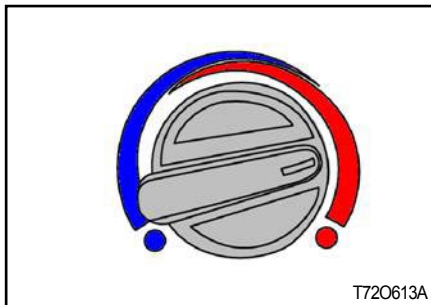

### ► TEMPERATURE CONTROL

Set temperature control as required, fully clockwise.

For maximum cool and fully counterclockwise for heat.

### ► AIR CON. SWITCH

To operate the air conditioner, the blower must be on. The blower speed temperature control and all vents must be adjusted to obtain the best cooling for the ambient temperature and dust conditions.

Under normal operating conditions, and the windows and doors closed, temperatures in the cab of 10 °F to 25 °F (6°C to 15 °C) less than the ambient temperature will occur. When operating the air conditioner system, the moisture level is decreased.

### NOTE

- During cold weather, with ambient temperature above 32 °F (0 °C) operate the air conditioner at least once per month, for a period of 10 to 15 minutes. This will lubricate the seals to prevent them becoming brittle and help prevent the loss of refrigerant from the system.
- The system is equipped with an environmentally safe refrigerant, R134a. Never recharge the air conditioning system with refrigerant other than R134a as this will result in loss of cooling and permanent damage to all air conditioning components.

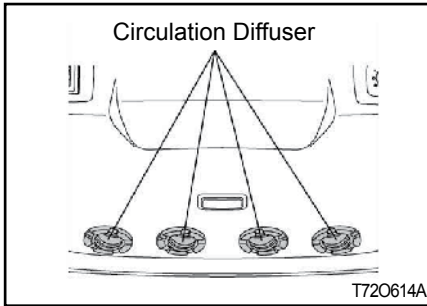

### ► CIRCULATION DIFFUSER

With the circulation vent set in any position outside air will still be pulled into the cab.

### ► HEATING SYSTEM

The heater is switched on and adjusted by rotating the control knob at the roof console, then switching on the blower and setting the selector at the preferred speed.

Warm the cab up quickly, the knob should be rotated fully clockwise and the blower set to speed 3.

The screen is demisted or defrosted by air directed through a slot vent. For defrost or fast demist, all other vents should be closed off.

#### IMPORTANT

- Ventilation is provided by a single blower unit serving both the heating system and the air conditioning system.
- After reaching the desired temperature adjust the system to suit your needs.

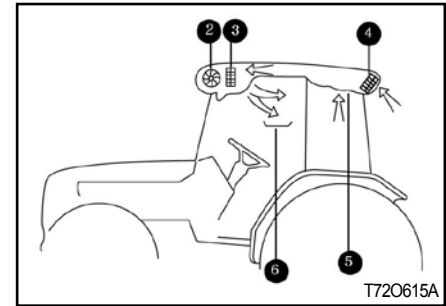

- ② Speed heating fan
- ③ Electric resistances
- ④ Air filter
- ⑤ Recirculation inlets
- ⑥ Pivotal air diffuser

#### NOTE

- For ideal system operation, the engine must run at 1,000 rpm.



### WARNING

- Before starting the engine, make sure the system is off (by turning off the ventilation fan) so as not to overload the battery.
- After the system at full power for a long period of time, never turn it off suddenly but let it first idle for about 20 seconds.

### ► HEATING SYSTEM CONFIGURATION

The heating system consist of two units:

1. Heater and blower unit installed behind roof console.
2. Power supplying set, consisting of an auxiliary alternator located front of the engine and driven by a belt directly linked to the engine pulley.

If the air does not come out from the diffusers right away as soon as the system is started, turn off immediately and identify the fault.

- ※ N.B: Never turn on the heating system when working in dusty environments.

### ► HEATING AIR CONDITIONER SYSTEM

The system is designed to ensure optimum temperature inside the cab and maximum comfort and safety for the operator.

However, it is advisable to consult our specialized workshops whenever repairs or adjustments need to be performed.

Do not approach the system with open flames, as any escape from the circuit may produce a lethal gas.

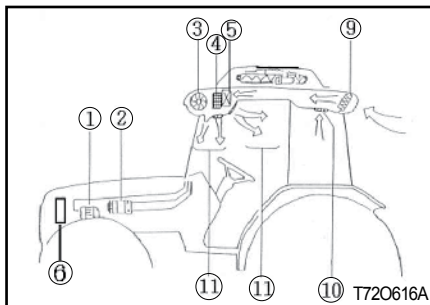

- ① Alternator
- ② Compressor
- ③ Speed fan
- ④ Electric resistance
- ⑤ Evaporator
- ⑥ Condenser
- ⑨ Air filter
- ⑩ Recirculation inlets
- ⑪ Pivotal air diffusers

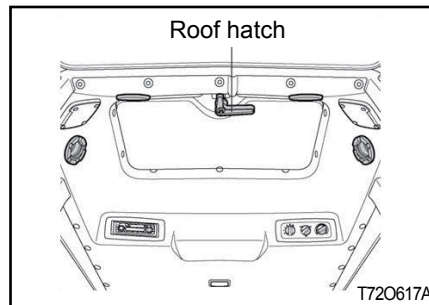

#### ► ROOF HATCH (IF EQUIPPED)

Ventilation-push the latch towards the front of the tractor and then push the hatch up.

Emergency Exit-Push firmly upwards to release the support struts from the lower retainer clips.

#### ► CIRCULATION DIFFUSER

With the circulation vent set in any position outside Air will still be pulled into the cab.



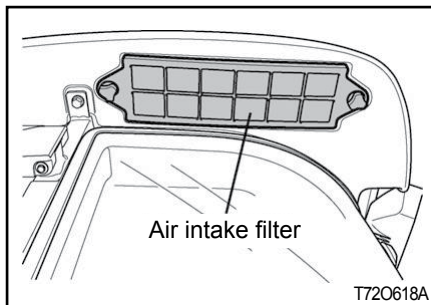

### ► CAB AIR INTAKE FILTER

The "paper" filter is not suitable for the treatment of pesticides and so must be replaced by an "active carbon" filter available optionally. Once the pesticide treatment is finished, it is necessary to once again replace the "Active carbon" filter with the paper filter, since this is the only type suited for filtering foreign particles from the air.

### ⚠ WARNING

- Cab air filters remove dust in the air, but are not capable of removing chemicals used in spraying crops or in weed control. Many chemicals used for these purposes are toxic when improperly used, and can be hazardous to operators and others in the area. Follow the instructions of manufacturers of both the equipment and the chemicals regarding prohibition of dust or spray, personal hygiene practices, and other precautions noted by the manufacturers.

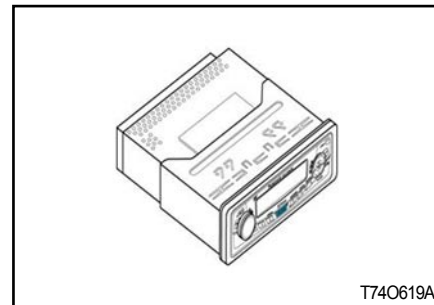

### ► RADIO, CD PLAYER (IF EQUIPPED)

For operation refer to the Radio, CD player manufacturers instructions.

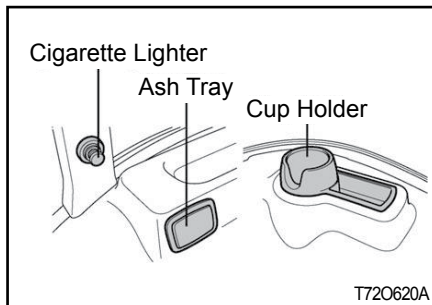

► **ASH TRAY**

Located at right side of near side window in cabin.

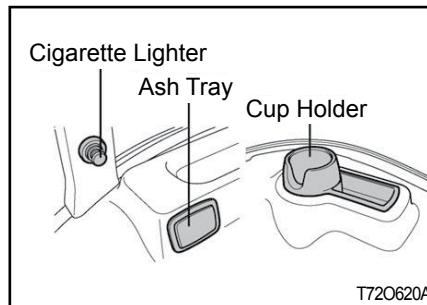

► **CUP HOLDER**

Put the bottles and Personal belongings.

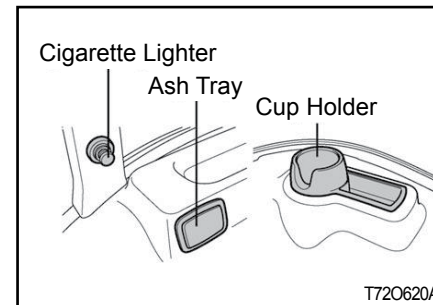

► **CIGARETTE LIGHTER**

Push the button. Use that is return to original position.



### ► CHECKING THE AIR CONDITIONING SYSTEM

1. Economic friendly refrigerant :  
R134a (0.7~0.85kg)

The presence of air and water in the system could jeopardize its efficiency.

- The air is uselessly compressed by the compressor and no cooling effect is produced.
- The moisture has a tendency rise to obstructions which prevent the cooling efficiency.

2. Check belt tension;

When finger pressure is applied to the mid-point between both pulleys.

3. Condenser fins must always be duly clean using water or an air set.

### ► CHECKING THE AIR CONDITIONING SYSTEM CHARGE

1. Check the refrigerant charge.
  - Run the engine at 1,500 rpm.
  - Set the air conditioning system in the coldest for 5 minutes.
  - Check the sight glass clear or cloud.

#### CAUTION

- If the air-con. is operated with not charged.
- The lubrication in the compressor can cause the damage.

2. Check the refrigerant with receive drier sight glass.



► **DIAGNOSING MALFUNCTIONS**

**1. TRACING FAULTS**

	<b>SYMPTOM</b>	<b>CONDITION</b>	<b>CAUSE</b>	<b>REMEDY</b>
1.Compressor	Abnormal sound	Inlet sound Outlet sound	• Insufficient Lub	• Replenish
			• Belt tension release	• Adjust
			• Release the bracket	• Tighten the bolts
			• Clutch fail	• Check
	Abnormal revolution	Inlet cause	• Damaged parts	• Check, Replace
			• Slip the clutch	• Check, Replace
			• Not Lub	• Replenish
		Outlet cause	• Belt tension released	• Adjust
	Refrigerant or oil leakage	Refrigerant or oil leakag	• Sealing washer damaged	• Replace
			• Head bolt released	• Tighten the bolts
			• D-ring damaged	• Replace
	Excessive pressure	Low, High pressur	• Insufficient refrigerator	• Adjust
• Compressor			• Replace	
2.Motor	Weak from pressure or don't work	Motor is normal	• Air inlet clogged	• Remove
			• Evaporator freezing	• Controlling minimum pressure
			• Ventilator switch damage	• Replace the switch
			• Compressor	• Replace
		Motor is abnormal	• Motor failure	• Replace
			• Wire cut	• Replace
		Air leakage	• Duct leakage	• Check, Tighten
		Unable to control the fan	Motor	• Air volume control switch failure
	Motor is abnormal		• Motor failure	• Replace



	SYMPTOM	CONDITION	CAUSE	REMEDY
3. Clutch	Noise	• Regular noise irregular noise	• Interference with pulley	• Control the compressor direction
	Disengage	• Engaged sometimes	• Wire defect	• Check wire
		• Engaged to push with hand	• Clutch gap large	• Adjust
		• No defect wire	• Low voltage	• Check battery
	Slip	• Slip during rotation	• Malfunction	• Replace
			• Low voltage	• Check battery
			• Oil stick at clutch	• Clean
		• Malfunction	• Replace	

## 2. How to check the air conditioning system with the needle of high low gauge

To connect with manifold pressure gauge can find the cause of air conditioning system.

Because manifold pressure gauge is various sensibly. (Ambient Temp. is based on 30~35 °C)

### CAUTION

- Operating E/G RPM 1500~2000 is must, and so to that you can check the correct cause and air conditioning. (In case below the figure of indicated pressure gauge has some clearance, confirm with approximate indicated needle data.)

## 3. Gauge pressure conversion

- lb/in<sup>2</sup> =PSI
- 1 kgf/cm<sup>2</sup>=14.22 lb/in<sup>2</sup> (Ex) 200 PSI=14 kgf/cm<sup>2</sup>



# **SPECIFICATION**

**1. SPECIFICATIONS.....7-2**



# SPECIFICATION

## 1. SPECIFICATIONS

### ► MAJOR SPECIFICATIONS

ITEM		RK74PSC	
ENGINE	Manufacturer	Deutz	
	Model	TCD2.9 L4	
	Type	Turbo	
	Number of Cylinders	6	
	Total Displacement	cm <sup>3</sup> (cu. in.)	2,900 (177.0)
	Gross Power	kW (HP)	55.4 (74)
	Rated Speed	rpm	2,200
	Maximum Torque	N-m (lbf-ft)@ rpm	300 (221.4) @ 1,600
Electrical System	Battery	12V, 110AH	
	Alternator	12V95A	
Drive Train	Transmission Type	Power-Shuttle	
	Number of Speeds	F16 / R16 (Creep interlock)	
	Brakes	Wet Disc	
	Steering	Hydrostatic	
	Clutch	Dry Single	
Pump Capacity (Main)		gpm (L/min)	10.3 (39.1)



ITEM			RK74PSC
Hydraulic System	Pump Capacity (Power Steering) gpm (L/min)		5.8 (22)
	Number of standard remote valves (Additional Option)		2
3 Point Hitch	Type		2
	Lift Capacity	Lift Points lb (kg)	5,115 (2,320)
		25-in. Behind Lift Points lb (kg)	3,418 (1,550)
	Lift Control Type		Position / Draft / Mech
PTO	Type		Independent
	Control		Electric/Hydro
	Mid (Option) rpm		N/A
	Rear rpm		540 / 750
	Shaft Diameter in. (mm)		1-3/8 (35), 6 Splines
Fluid Capacities	Fuel Tank gal. (L)		23.8 (90)
	Cooling System qt. (L)		10.6 (10)
	Crankcase (with filter) qt. (L)		8.5 (8)
	Trans. & Hydr. System gal. (L)		18.0 (68)
	Front Axle qt. (L)		17.4 (16.4)





# SPECIFICATION

ITEM			RK74PSC
Dimensions	Overall length with 3-Point Hitch	in. (mm)	157.5 (4,002)
	Overall width	in. (mm)	76.4 (1,940)
	Overall Height	in. (mm)	103.3 (2,624)
	Wheelbase	in. (mm)	86.1 (2,188)
	Min. Ground Clearance	in. (mm)	18.3 (465)
	Min. Turning Radius without brakes	in. (mm)	162.8 (4,135)
Weight with ROPS or Cab			6,052 (2,745)
Tire	Front	R1 / R2 / R3 / R4	11.2-24 / - / - / - /
	Rear	R1 / R2 / R3 / R4	16.9-30 / - / - / - /



**▶ TRAVELING SPEED**

Traveling Speed @ 2200 rpm : km/h (mph)

OPERATING THE LEVER			TRAVELING SPEED	
Creep	Range Shift	Main shift	Forward	Reverse
On	L	1	0.39(0.28)	0.28(0.20)
		2	0.57(0.40)	0.42(0.30)
		3	0.82(0.58)	0.6(0.43)
		4	1.09(0.77)	0.79(0.56)
	M	1	1.24(0.88)	0.90(0.64)
		2	1.82(1.29)	1.33(0.94)
		3	2.61(1.85)	1.9(1.35)
		4	3.48(2.47)	2.54(1.80)
	H	1	3.95(2.80)	2.88(2.04)
		2	5.82(4.13)	4.24(3.01)
		3	8.35(5.92)	6.09(4.32)
		4	11.13(7.90)	8.12(5.76)
Off	L	1	1.28(0.91)	0.94(0.67)
		2	1.89(1.34)	1.38(0.98)
		3	2.71(1.92)	1.98(1.40)
		4	3.62(2.57)	2.64(1.87)
	M	1	4.1(2.91)	2.99(2.12)
		2	6.04(4.29)	4.41(3.13)
		3	8.66(6.14)	6.32(4.48)
		4	11.55(8.20)	8.43(5.98)
	H	1	13.13(9.32)	9.58(6.80)
		2	19.33(13.72)	14.10(10.00)
		3	27.73(19.68)	20.23(14.35)
		4	36.97(26.23)	26.97(19.14)

※ The specifications are subject to change for improvement without notice.



## ► NOISE LEVELS

The tractor is approved in accordance with the applicable EC Directives.

### To avoid increased noise levels proceed as follows:

- After maintenance operations or repairs refit all the sound-deadening panels and materials correctly
- Do not make changes to the tractor that may lead to an increase in noise emissions.
- Beware of any anomalous noise or vibration if you notice anomalous noise or vibration, park the tractor in a safe position and perform the stopping procedure. Inform maintenance personnel of the situation. Avoid prolonged operation.

### Reference standards for the measurement of noise levels:

- The maximum driver-perceived noise level, with the engine at normal operating temperature and measured in accordance with the test method described in the European Directive 2009/76EC

MODEL	NOISE LEVELS	
	Maximum noise level in CAB with Doors open (Roof hatch and front And rears windows open), db(A)	Maximum noise level in CAB with doors closed, db(A)
RK74PSC	81.5	82

- The maximum noise level measured with the tractor in motion and the tractor stationary, measured in accordance with the method described in European directive 2009/63/EC.

MODEL	NOISE LEVELS	
	Maximum external noise level With tractor moving, db(A)	Maximum external noise level With tractor stationary, db(A)
RK74PSC	80	77.5



► **VIBRATION REFERRED TO THE OPERATOR POSITION**

The value is referred to the amount of mechanical vibration transmitted by the tractor to WHOLE-BODY as defined by UNI ISO2631-1:2008.

Said value must be utilised for assessment of the vibration exposure risk, but it cannot cover all the possible conditions of use of the tractor since it may vary in accordance with parameters that are not always related to the tractor(terrain, implements, etc.) If the risk assessment cannot be considered to be exhaustive or if the risk may exceed the values defined in 2002/44/EC, the use of a vibration meters prescribed.

**In order to minimise the vibration transmitted to the whole-body the following best practice rules should be observed**

- Use the most suitable implement for the tractor and the task in hand
- Adjust the seat to suit your weight and stature
- Periodically check the condition of the cab suspensions and renew them if damaged
- Check tyre inflation pressure
- Use front axle suspensions, if fitted
- During transfers, adjust tractor speed in order to minimise the vibration level.

The seat vibration values, as obtained from the seat approval in compliance with 78/764/EEC (amended by 1999/57/EC) are shown in the following table.



**TECHNICAL DATA**

Input vibration : Category A, Class I  
And Class II

Ambient temperature : 23°C

Seat type			Corrected vibration level on seat
WOOCHANG W2100	Light driver	59kg	1.18 m/sec <sup>2</sup>
	Heavy driver	98kg	0.95 m/sec <sup>2</sup>
Grammer DS 44/1HB	Light driver	59kg	Refer to EEC certificate: e1-100506
	Heavy driver	98kg	



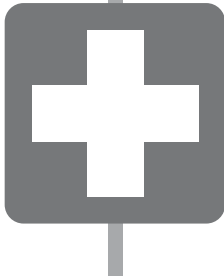

## **TROUBLESHOOTING**

- 1. ENGINE TROUBLESHOOTING..... 8-2**
- 2. CLUTCH, BRAKE AND HYDRAULIC SYSTEM  
TROUBLESHOOTING..... 8-6**
- 3. STEERING WHEEL AND ELECTRIC  
INSTRUMENTS TROUBLESHOOTING..... 8-7**
- 4. TOWING THE TRACTOR ..... 8-8**



## 1. ENGINE TROUBLESHOOTING

	TROUBLE	PROBABLE CAUSE	SOLUTION
Engine	The start motor does not run even when turning the main switch.	<ul style="list-style-type: none"> <li>• Clutch pedal released</li> <li>• PTO switch set to ON position</li> <li>• Defective safety switch</li> <li>• Battery discharged</li> <li>• Loose terminal</li> <li>• Faulty switch</li> <li>• Defective start motor</li> </ul>	<ul style="list-style-type: none"> <li>• Depress the clutch pedal</li> <li>• Set the PTO switch to the OFF position</li> <li>• Have it repaired or replaced by workshop</li> <li>• Charge the battery</li> <li>• Check for looseness and corrosion. Clean, tighten and apply grease</li> <li>• Have it repaired or replaced by workshop</li> <li>• Have it repaired or replaced by workshop</li> </ul>
	The start motor runs but its speed cannot be increased	<ul style="list-style-type: none"> <li>• Weak battery</li> <li>• Poor ground</li> <li>• Incorrect viscosity of engine oil</li> </ul>	<ul style="list-style-type: none"> <li>• Charge the battery</li> <li>• Clean the contact and connect the ground firmly</li> <li>• Change engine oil with proper viscosity</li> </ul>
	The start motor runs but the engine cannot be started	<ul style="list-style-type: none"> <li>• Air in fuel system</li> <li>• Clogged fuel filter</li> <li>• No delivery of fuel</li> <li>• Defective engine</li> <li>• Defective key stop unit</li> </ul>	<ul style="list-style-type: none"> <li>• Bleed the system</li> <li>• Clean or replace the filter</li> <li>• Open the cock to add fuel</li> <li>• Have it repaired by workshop</li> <li>• Have it repaired by workshop</li> </ul>
	The engine runs irregularly	<ul style="list-style-type: none"> <li>• Air in fuel system</li> <li>• Clogged fuel filter</li> </ul>	<ul style="list-style-type: none"> <li>• Bleed the system</li> <li>• Clean or replace the filter</li> </ul>



TROUBLE		PROBABLE CAUSE	SOLUTION
Engine	The engine runs irregularly	• Clogged injection nozzle	• Have it repaired by workshop
		• Fuel leak at pipe	• Tighten the clamp, replace the pipe and machine and attach the copper washer
		• Poor fuel injection quality	• Have it repaired by workshop
	Engine stops at low speed	• Defective injection pump	• Have it repaired by workshop
		• Incorrect clearance of engine valve	• Have it repaired by workshop
		• Low idle speed	• Adjust it to the standard speed
		• Faulty nozzle	• Have it repaired by workshop
	The engine overruns	• Restricted governor	• Have it repaired by workshop
		• Oil rise	• Have it repaired by workshop
	The engine stalls suddenly	• Low fuel level	• Add fuel and bleed the system
		• Faulty nozzle	• Have it repaired by workshop
		• Engine seizure by insufficient oil or poor lubrication	• Have it repaired by workshop
The engine is over-heated	• Insufficient coolant amount	• Add coolant	
	• Damaged fan belt	• Replace the belt	
	• Clogged radiator	• Clean the radiator	
	• Insufficient engine oil	• Check and add	





## TROUBLESHOOTING

	TROUBLE	PROBABLE CAUSE	SOLUTION
Engine	The engine produces white smoke	• Clogged air cleaner	• Check and clean it
		• Excessive engine oil amount	• Check and set it to the proper amount
		• Insufficient fuel supply amount	• Have it repaired by workshop
	The engine produces black smoke	• Low quality fuel	• Add the specified fuel
		• Excessive fuel amount delivery	• Have it repaired by workshop
		• Insufficient nozzle pressure	• Have it repaired by workshop
	The engine does not produce sufficient power	• Clogged or carbon on nozzle tip	• Have it repaired by workshop
		• Insufficient compression or gas leak from valve seat	• Have it repaired by workshop
		• Improperly adjusted valve clearance	• Have it repaired by workshop
		• Incorrect injection timing	• Have it repaired by workshop
		• Low fuel level	• Add fuel
		• Clogged air cleaner	• Clean the element
	The oil warning lamp comes on during driving	• Low engine oil level	• Add to the specified level
		• Low viscosity of engine oil	• Change engine oil with proper viscosity
		• Faulty pressure switch	• Replace the switch



TROUBLE		PROBABLE CAUSE	SOLUTION
Engine	The oil warning lamp comes on during driving	• Defective oil pump	• Have it repaired by workshop
		• Clogged oil filter element	• Replace the oil filter
	The charge warning lamp comes on during driving	• Defective wiring	• Check for loose or missing terminal, short circuit and poor ground and repair as necessary
		• Defective alternator	• Have it repaired by workshop
		• Defective battery	• Replace the battery
		• Damaged fan belt	• Replace the belt



## 2. CLUTCH, BRAKE AND HYDRAULIC SYSTEM TROUBLESHOOTING

SYMPTOM		CAUSE	REMEDY
Clutch	The clutch slips	<ul style="list-style-type: none"> <li>• Incorrect adjustment</li> <li>• Worm or burnt lining</li> </ul>	<ul style="list-style-type: none"> <li>• Adjust to correct free play</li> <li>• Contact dealer for repair</li> </ul>
	The clutch does not disengage	<ul style="list-style-type: none"> <li>• Incorrect adjustment</li> <li>• Rusty clutch lining</li> </ul>	<ul style="list-style-type: none"> <li>• Adjust to correct free play</li> <li>• Contact dealer for repair</li> </ul>
Brake	Brake not working	<ul style="list-style-type: none"> <li>• Incorrect free play</li> <li>• Worm or burnt lining</li> <li>• Left and right gap different</li> </ul>	<ul style="list-style-type: none"> <li>• Adjust to correct free play</li> <li>• Contact dealer for repair</li> <li>• Equalize</li> </ul>
	Brake pedal not returning	<ul style="list-style-type: none"> <li>• Faulty return spring</li> <li>• Lack of grease on the joints</li> </ul>	<ul style="list-style-type: none"> <li>• Replace spring</li> <li>• Remove rust and lubricate with grease</li> </ul>
Hydraulic system	Hydraulics are not lifting	<ul style="list-style-type: none"> <li>• Engine revs. too low</li> <li>• Lack of transmission</li> <li>• Oil</li> <li>• Air leaking in from a pipe</li> <li>• Clogged suction filter</li> <li>• Faulty pump</li> <li>• Faulty hydraulic valve</li> <li>• Faulty cylinder</li> </ul>	<ul style="list-style-type: none"> <li>• Increase engine revs.</li> <li>• Top up the oil to the correct level</li> <li>• Repair or replace pipe or replace O ring on joint and tighten</li> <li>• Clean and change oil</li> <li>• Contact dealer for repair</li> <li>• Contact dealer for repair</li> <li>• Contact dealer for repair</li> <li>• Contact dealer for repair</li> </ul>
	Oil leak from pipe	<ul style="list-style-type: none"> <li>• Loose pipe joint</li> <li>• Cracked pipe</li> </ul>	<ul style="list-style-type: none"> <li>• Tighten joint</li> <li>• Replace or repair pipe</li> </ul>
	When lifting the relief valve whistles	<ul style="list-style-type: none"> <li>• The stopper has slipped down</li> </ul>	<ul style="list-style-type: none"> <li>• Adjust the stopper</li> </ul>

※ For any other hydraulic problems please consult your dealer who has the correct equipment to diagnose and repair the system.



### 3. STEERING WHEEL AND ELECTRIC INSTRUMENTS TROUBLESHOOTING

	SYMPTOM	CAUSE	REMEDY
Steering wheel	Steering wheel shaking	<ul style="list-style-type: none"> <li>• Wrong toe-in</li> <li>• Unequal tire pressure</li> <li>• Loose component</li> </ul>	<ul style="list-style-type: none"> <li>• Adjust toe-in</li> <li>• Inflate both to correct pressure</li> <li>• Tighten or replace if worn</li> </ul>
	Excessive play in the steering	<ul style="list-style-type: none"> <li>• Worn steering shaft</li> <li>• Worn components</li> </ul>	<ul style="list-style-type: none"> <li>• Contact dealer for repair</li> <li>• Contact dealer for repair</li> </ul>
Electric instruments	Flat battery	<ul style="list-style-type: none"> <li>• Faulty wiring</li> <li>• Faulty alternator</li> <li>• Faulty regulator</li> <li>• Broken or loose fan belt</li> </ul>	<ul style="list-style-type: none"> <li>• Repair, reconnect or tighten as needed</li> <li>• Contact dealer for repair</li> <li>• Contact dealer for repair</li> <li>• Replace or adjust</li> </ul>
	Before anything else, check the electrolyte level of the battery and the connections. Top up if required and clean and retighten the terminal		
	Dim head lights	<ul style="list-style-type: none"> <li>• Low battery</li> <li>• Faulty wiring</li> </ul>	<ul style="list-style-type: none"> <li>• Charge or replace</li> <li>• Repair or replace as needed</li> </ul>
	Headlights not working	<ul style="list-style-type: none"> <li>• Blown bulb</li> <li>• Blown fuse</li> <li>• Faulty contact</li> </ul>	<ul style="list-style-type: none"> <li>• Replace bulb</li> <li>• Replace fuse</li> <li>• Repair or replace and check the earth</li> </ul>
	Horn not working	<ul style="list-style-type: none"> <li>• Faulty horn button</li> <li>• Faulty wiring</li> <li>• Faulty horn</li> </ul>	<ul style="list-style-type: none"> <li>• Replace button</li> <li>• Repair or replace</li> <li>• Replace</li> </ul>
Dicator not working	<ul style="list-style-type: none"> <li>• Blown bulb</li> <li>• Faulty flasher unit</li> <li>• Faulty wiring</li> </ul>	<ul style="list-style-type: none"> <li>• Replace bulb</li> <li>• Replace unit</li> <li>• Repair or replace</li> </ul>	



### 4. TOWING THE TRACTOR

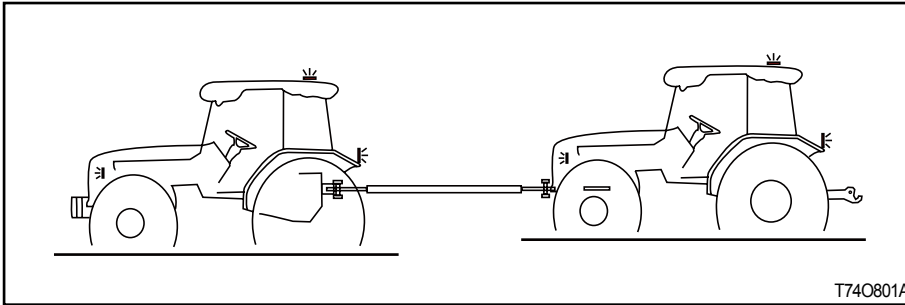

The tractor can be towed only for short distances, such as, for example, from inside to outside a building.

A broken down tractor should be towed for the minimum indispensable distance to remove it from potentially dangerous conditions. Observe all legal provisions as envisaged in the highway code relative to national legislation regarding towing manoeuvres.

#### CAUTION

- We recommend transporting the tractor on a low loader in the case of longer transport distances. Comply with the maximum width and height regulations for road transport. Check that the loader is suitable for the weight of the tractor to be transported.

#### CAUTION

- An operator must always be at the tractor's controls when the tractor is being towed.

#### DANGER

- NEVER permit other persons to access the tractor operator position during towing.



## ► TOWING WITH THE ENGINE RUNNING

Towing with the engine running can be performed if forced gearbox lubrication is ensured:

- Engine speed between 1200 - 1300 rpm.
- Maximum towing speed 8 km/h
- Maximum towing distance 1 km

For towing the tractor use only a standard bar applied to the front towing hitch approved by the manufacturer.

Make sure to use the correct pin for the towing hitch and that it is secured with its locking pin.

Clean all lights required for road use, front and rear, and make sure they are in working order

Before starting towing check the following conditions:

- Unhitch any implement from the tractor;
- Lock the two brake pedals together with the connecting latch;

- Disengage the power take-off and differential locks;
- Set the shuttle control lever and gear lever to neutral;
- Move the range lever to the "fast" position;
- Move the creeper lever to neutral;
- Display the SMV (Slow Moving Vehicle) sign and turn on the rotating beacon and hazard lights

### WARNING

- Switch on the hazard warning lights and revolving warning lights. Affix suitable notices indicating that the tractor is being towed. Observe and follow the relevant national regulations. Observe local safety regulations.

During road transfers observe the following instructions:

- Wait until traffic thins before joining the road. Exert caution in the proximity of unregulated intersections. Slow down until you have a clear view in both directions.
- Keep in your lane and drive as close as possible to the kerb. If a tailback builds up behind you pull into a lay-by as soon as possible to allow the traffic to pass
- When stopping the tractor (in any circumstances) apply the parking brake.
- Travel speed must ALWAYS be such as to allow complete control and stability of the tractor in all conditions.

### DANGER

- Never attempt to tow the tractor with ropes (including steel ropes) because rope breakage can cause serious injury.



### ► TOWING WITH THE ENGINE OFF

#### IMPORTANT

- With engine stopped and with forced gearbox lubrication system inoperative the tractor can be transferred to a service centre only when loaded onto a transporter.

With engine stopped and with forced gearbox lubrication system inoperative the tractor should not be towed except when safety is at risk.



## **APPENDIX**

<b>1. POSITION OF THE FUSE.....</b>	<b>9-2</b>
<b>2. WIRING DIAGRAM OF THE ELECTRIC INSTRUMENT ...</b>	<b>9-2</b>
<b>3. TRACTOR HISTORY CARD .....</b>	<b>9-3</b>
<b>4. SERVICE RECORD .....</b>	<b>9-4</b>
<b>5. DAILY OPERATION LOG .....</b>	<b>9-5</b>
<b>6. PART REPLACEMENT RECORD .....</b>	<b>9-6</b>
<b>7. ENGINE OIL MANUFACTURER .....</b>	<b>9-7</b>
<b>8. COOLANT MANUFACTURER .....</b>	<b>9-10</b>















## 7. ENGINE OIL MANUFACTURER

MANUFACTURER	BRAND NAME	SAE CLASS
<b>DEUTZ AG</b>	<b>DEUTZ OEL Rondon 10W40 low SAPS</b>	<b>10W-40</b>
AGCO	AGCO Parts Premium Grade Plus 10W-40	10W-40
	Fendt Premium Grade 15W-40	15W-40
	Fendt Premium Grade 10W-40	10W-40
ARAL AG	ARAL Mega Turboral VR 10W-40	10W-40
	ARAL Turboral VR 15W-40	15W-40
Bahrain Petroleum Company	Frontier Megatek	10W-40
BayWa AG	TECTROL Super Truck Plus FE 1040 LA	10W-40
	TECTROL Super Truck VD Plus 1040	10W-40
BP Plc.	BP Vanellus Max Eco 15W-40	15W-40
Bucher AG Langenthal	MOTOREX Focus CF	15W-40
	MOTOREX Focus CF	10W-40
	MOTOREX Farmer LA	10W-40
CONDAT Lubrifants	VICOM NOVA 10W30	10W-30
Castrol Limited	Castrol CRB Turbo G4 15W-40	15W-40
	Castrol Enduron Global 15W-40	15W-40
	Castrol Vecton 15W-40 CJ-4	15W-40
Carl Harms Mineralöle	Oilfino Econ T 9000 10W-40	10W-40
Chevron Lubricants	Caltex Delo 400 LE 15W-40	15W-40
	Caltex Delo XLE Multigrade 10W-40	10W-40
Chevron Lubricants	Chevron Delo 400 LE 15-W40	15W-40
	Delo 400 XLE Synblend SAE 10W-30	10W-30
	Texaco Ursa Ultra LE 15W-40	15W-40
	Texaco Ursa Ultra X 10W-30	10W-30
	Texaco Ursa Ultra X 10W-40	10W-40
	Ursa Ultra LE 10W-30	10W-30
ELF Lubricants	ELF Agritec ZS FE	10W-30
ENI S.p.A.	Eni i-Sigma top MS 15W-40	15W-40
EUROLUB GmbH	EUROLUB Supermax 10W/40	10W-40
Eissing Mineralöl GmbH	Eco Truck LA 10W40	10W-40
ExxonMobil Corp.	Mobil Delvac 1 ESP	5W-40
Finke Mineralölwerk GmbH	Aviaticon Finko Super Truck LA 10W/40	10W-40
	Aviaticon Turbo LA Plus 10W/40	10W-40
	Aviaticon Turbo Super Plus 15W/40	15W-40

MANUFACTURER	BRAND NAME	SAE CLASS
Fuchs Petrolub AG	TITAN Cargo 10W-30	10W-30
	TITAN Cargo 15W-40	15W-40
GB LUBRICANTS	GB INTERCOOLER LSC 15W-40	15W-40
Georg Oest Mineralölwerke	OEST Dimo Top LS SAE 10W-40	10W-40
Gulf Oil International	Gulf Superfleet XLE SAE 10W-40	10W-40
	Gulf Superfleet Synth XLE SAE 10W-40	10W-40
Kuwait Petroleum	Q8 T760 10W-30	10W-30
	Q8 T904 10W-40	10W-40
	TURDUS POWERTEC 1100 15W40	15W-40
LOTOS S.A.	TURDUS POWERTEC 5100 10W40	10W-40
	TURDUS POWERTEC SYNTHETIC PLUS 10W40	10W-40
Meguin GmbH & Co. KG	Megol Motorenoel Low SAPS	10W-40
Minerva Oil	SYNTHOTRUCK 10W40	10W-40
MORRIS Lubricants	Ring Free Ultra 10W/40	10W-40
	Ring Free Ultra Plus 15W/40	15W-40
OMV	OMV truck blue GS SAE 10W-30	10W-30
	OMV truck blue GS SAE 10W-30	10W-40
Orlen Oil	Platinum Uitor Progress 10W-40	10W-40
Panolin AG	Panolin Universal LA-X	10W-40
Petro-Canada Lubricants	Duron-E Synthetic	10W-40
	Duron UHP 10W-40	10W-40
Petronas Lubricants International	URANIA ECOTECH 10W-40	10W-40
	URANIA SUPREMO CJ-4	15W-40
Petróleos de Portugal, Petrogal S.A	Galp Galáxia LD Supra	15W-40
Phillips 66 Lubricants.	Triton ECT Full Synthetic 5W-40	5W-40
Ravensberger Schmierstoffvertrieb	RAVENOL EURO VI Truck	10W-40
Rosneft Lubricants	Rosneft Revolux D5	15W-40



# APPENDIX

MANUFACTURER	BRAND NAME	SAE CLASS
ROWE Mineralölwerk GmbH	ROWE HIGHTEC TRUCKSTAR SAE 10W-40 HC-LA	10W-40
	ROWE HIGHTEC TRUCKSTAR SAE 10W-40 MULTI-LA	10W-40
Shell International	Pennzoil Long-Life Gold	15W-40
	Shell Rimula R5 LE	10W-30
	Shell Rimula R5 LE	10W-40
	Shell Rimula R4 L	15W-40
	Shell Rimula RT4 L	15W-40
	Shell Rimula Super	15W-40
	Shell Rotella T3	15W-40
	Shell Rotella T Triple Protection	15W-40
SRS Schmierstoff Vertrieb GmbH	SRS Cargolub Leichtlauf-Motorenöl	10W-40
	SRS Turbo-Rekord plus FE	10W-40
	SRS Turbo-Rekord plus	10W-40
TEDEX S.A.	Tedex SHPD VDS4 LSP Motor Oil	15W-40
TOTAL Lubricants	TOTAL Rubia TIR 7900 FE	10W-30
	TOTAL Rubia Works 2000 FE	10W-30
	TOTAL Rubia Works 2000	10W-40
	TOTAL Star Max FE	10W-30
	TOTAL Tractagri HDZ FE	10W-30
TOTAL Lubricants	TOTAL Tractagri HDZ	10W-40
Transnational Blenders B.V.	Motor Oil SCR	10W-40
	Engine Oil Synthetic UHPD E6	10W-30
	Engine Oil Synthetic UHPD E6	10W-40
Unil Opal	PALLAS 725	10W-40
Zeller - Gmelin GmbH & Co. KG	Divinol Multimax Plus 10W40	10W-40
<b>DEUTZ AG</b>	<b>DEUTZ EOL DQC4 - 5W30 -UHP</b>	<b>5W-30</b>
BayWa AG	TECTROL Super Truck 530	5W-30
Chevron Lubricants	Ursa Premium FE 5W-30	5W-30
ENI S.p.A.	AGIP SIGMA Trucksint TFE	5W-30
Fuchs Petrolub AG	TITAN Cargo SL	5W-30

MANUFACTURER	BRAND NAME	SAE CLASS
General Petroleum	DEOGEN Semi-Synthetic	10W-40
IGOL FRANCE	PROLANDER AGR1 150 XTREM	10W-40
LOTOS S.A.	TURDUS POWERTEC 5000 5W30	5W-30
LUKOIL Lubricants	LUKOIL Avantgarde Professional	5W-30
Meguin GmbH & Co. KG	Megol Motorenoel UHPD Truck	5W-30
OMV	OMV super truck SAE 5W-30	5W-30
OMV Petrol Ofisi	PO Maximus 10W40	10W-40
Opet Fuchs Madeni YAG SAN. VE TIC. A.S	FullPro HT Syn	10W-40
Orlen Oil	Platinum Ultor Max 5W-30	5W-30
Petronas Lubricants International	URANIA MAXIMO	5W-30
RA.M. OIL SPA	DUGLAS OIL ULTRA HC 10W-40 UHPDO	10W-40
REPSOL	REPSOL Diesel Turbo VHPD 5W-30	5W-30
Shell International	Shell Rimula R5 M	10W-40
	Shell Rimula R6 M	10W-40
	Shell Rimula R6 MS	10W-40
Shell International	Shell Rimula R6 ME	5W-30
SRS Schmierstoff Vertrieb GmbH	SRS Cargolub TFG	10W-40
Unil Opal	SRS Cargolub TFL	5W-30
	LCM 800 10W40	10W-40
Valvoline	Valvoline ProFleet SAE 5W-30	5W-30
ADDINOL	ADDINOL Extra Truck MD 1049 LE	10W-40
ARAL AG	ARAL Mega Turboral LA 10W-40	10W-40
Aseol Suisse AG	Asetruck LA 10W-40	10W-40
ASTRIS S.A.	ASTRIS DIESEL ADC-X SAE 10W-40	10W-40
AVIA	Turbosynth Low SAPS 10W-40	10W-40
	Turbosynth HT LS 10W-40	10W-40
BayWa AG	TECTROL Super Truck Plus E6 530	5W-30
	TECTROL Super Truck Plus 1040	10W-40
	TECTROL Super Truck Plus XL 1040	10W-40
BP Plc	BP Vanellus Max Eco 5W-30	5W-30
	BP Vanellus Max Eco 10W-40	10W-40



MANUFACTURER	BRAND NAME	SAE CLASS
Bucher AG Langenthal	MOTOREX Focus QTM	10W-40
	MOTOREX Nexus FE	5W-30
Castrol Limited	Castrol Enduron Low SAPS 10W-40	10W-40
	Castrol Vecton Fuel Saver 5W-30 E6/E9	5W-30
Castrol Limited	Castrol Vecton Long Drain 10W-40 E6/E9	10W-40
	Castrol Vecton Long Drain 10W-30 E6/E9	10W-30
CHAMPION CHEMICALS N.V.	CHAMPION OEM SPECIFIC 5W30 UHPD	10W-30
Chevron Lubricants	Chevron Delo 400 LE Synthetic 5W-30	5W-30
	Delo 400 XLE Synthetic SAE 5W-30	5W-30
	Texaco Ursa Ultra XLE 5W-30	5W-30
EMKA Schmiertechnik GmbH	EMKA Cargo LSP 10W40	10W-40
ENI S.p.A.	Eni i-Sigma top MS 10W-40	10W-40
	Eni i-Sigma top MS 5W-30	5W-30
ExxonMobil Corp.	Mobil Delvac 1 LE	5W-30
	Mobil Delvac XHP ESP 10W-40	10W-40
	Mobil Delvac XHP LE 10W-40	10W-40
Finke Mineralölwerk GmbH	Aviaticon Finko Premium Truck 5W/30	5W-30
	Aviaticon Finko Super Truck LA 5W/30	5W-30
Fuchs Petrolub AG	TITAN Cargo EU6 5W-30	5W-30
	TITAN Cargo Maxx 5W-30	5W-30
	TITAN Cargo Maxx 10W-40	10W-40
Georg Oest Mineralölwerke	OEST Dimo LS SAE 10W-40	10W-40
Gulf Oil International	Gulf Superfleet ULE SAE 5W-30	5W-30
Hessol Lubrication GmbH	Hessol Dimo Extra	10W-40
	Q8 T905 10W-40	10W-40
Kuwait Petroleum	Q8 T910 5W-30	5W-30
	Q8 T910 5W-30	5W-30
LUKOIL Lubricants	LUKOIL Avantgarde Professional LS	5W-30
	LUKOIL Avantgarde Professional LS	10W-40
Minerva Oil	ALLTRUCK 5W-30	5W-30
Modriča Oil Refinery s.c.	MAXIMA EURO 5+	10W-40
MORRIS Lubricants	ECOSYN 10W-40	10W-40

MANUFACTURER	BRAND NAME	SAE CLASS
New Process AG – Schmierstoffe	SUPER DALLAS SYNKAT SAE 10W-40	10W-40
	OMV	OMV truck blue ET SAE 10W-40
Panolin AG	Panolin Diesel Synth	10W-40
	Panolin Diesel Synth EU-4	10W-40
	Panolin Ecomot	5W-30
Petro-Canada Lubricants	Duron-E UHP 5W-30	5W-30
Petronas Lubricants International	URANIA FE LS	5W-30
PHI Oil GmbH	Motodor LSP Gold 5W30	5W-30
	Motodor LSP Gold 10W40	10W-40
REPSOL	REPSOL Diesel Turbo VHPD MIS SAPS 5W-30	5W-30
	REPSOL ECOTECH PREMIUM LOW SAPS 10W40	10W-40
ROWE Mineralölwerk GmbH	ROWE HIGHTEC TRUCKSTAR SAE 5W-30 HC-LA	5W-30
Smeermiddelen-Industrie "De Oliebron" B.V.	Tor Turbosynth LSP Plus 10W40	10W-40
SRS Schmierstoff Vertrieb GmbH	SRS Cargolub TLA	10W-40
	SRS Cargolub TLS	5W-30
	SRS Cargolub TLS plus	5W-30
	SRS Turbo Diesel LA	10W-40
Shell International	Shell Rimula R6 LME	5W-30
	Shell Rimula R6 LM	10W-40
TOTAL Lubricants	TOTAL Rubia Works 2500	10W-40
Unil Opal	PALLAS 900	10W-40
Valvoline	Valvoline ProFleet LS SAE 10W-40	10W-40
	Valvoline ProFleet LS NTI SAE 10W-40	10W-40
Wunsch Öle GmbH	Wunsch TLA-Diesel PLUS SAE 10W-40	10W-40
Wolf Oil Corporation N.V.	WOLF OFFICIALTECH 5W30 UHPD	5W-30





## 8. COOLANT MANUFACTURER

MANUFACTURER	BRAND NAME	MARKETING AREA
DEUTZ AG	DEUTZ Kühlsystemsenschutzmittel	Weltweit/ Worldwide

MANUFACTURER	BRAND NAME	MARKETING AREA
DEUTZ AG	DEUTZ Kühlsystemsenschutzmittel	Weltweit / Worldwide
ARAL	Antifreeze Extra	
AVIA	AVIA ANTIFREEZE APN	
BASF	Glysantin® G48®	
BVG-Blume GmbH	Mofin Kühlerfrostschutz M48 Premium Protect	
BUCHER	MOTOREX COOLANT G48	Schweiz / Switzerland
Castrol	Castrol Radicool NF	
	Castrol Radicool NF Premix *	
ESSO	ESSO Antifreeze Extra *	
Exxon Mobil	Mobil Antifreeze Extra	
FUCHS Petrolub AG	MAINTAIN FRICOFIN	
INA Industrja	INA Antifriz AL Super	Afrika / Africa
Mitan Mineralöl GmbH	Alpine C48	
OMV	OMV coolant plus	
Opet Fuchs Madeni Yag San ve Tic. A.S	Antifreeze Special	
TOTAL	Glacelf MDX	
Unico Ltd	Shell Triguard PM *	
Unico Ltd	Engmans Ready to Use Antifreeze and Coolant*	
VALVOLINE	G48 Antifreeze	
	Zerex G48	
EUROLUB GmbH	EUROLUB Kühlerschutz d-48 Extra	
INEOS	INEOS C 2270-1	
AGIP	Antifreeze special	
ARTECO	Havoline XLC	Europa, Südamerika / Europe, South America
CALTEX	Caltex Extended Life Coolant	
	Delo Extended Life Coolant	
	Caltex Extended Life Coolant -N	mit Nitrit / with nitrite
	Delo Extended Life Coolant -N	mit Nitrit / with nitrite



MANUFACTURER	BRAND NAME	MARKETING AREA
Chevron	Havoline Dexcool Extended Life Coolant	USA / US
	Havoline XLC	Osteuropa, Südamerika / East Europe, South America
	Delo Extended Life Coolant NF	Osteuropa / East Europe
	Ursa Extended Life Coolant NF	Südamerika / South America
	Texaco Extended Life Coolant	mit Nitrit und Molybdat / with nitrite and molybdat
	Delo Extended Life Coolant	mit Nitrit und Molybdat / with nitrite and molybdat
	HDAX Extended Life Coolant	mit Nitrit und Molybdat / with nitrite and molybdat
	Ursa Extended Life Coolant	mit Nitrit und Molybdat / with nitrite and molybdat
FUCHS Petrolub AG	MAINTAIN FRICOFIN LL	
GAZPROMNEFT-LUBRICANTS LTD	G-Energy Antifreeze SNF	
LLK Finland Oy	Glycold XLC	
Mol-Lub Ltd.	EVOX Premium Concentarte	
Opet Fuch Madeni Yag San ve Tic. A.S	Opet Extended Life Antifreeze	
Orvema B.V.	Ovrema Protex LL	Niederlande / The Netherland
Swd Schmierstoffvertrieb GmbH	Swd Rheinol Antifreeze GW-12 Konzentrat	
TOTAL	Glacelf Auto Supra	
	Total Organifreeze	
Technoform	CoolStream Premium C	Osteuropa / East Europe
	CoolStream Premium 40	Osteuropa / East Europe
	CoolStream Premium 65	Osteuropa / East Europe
YACCO	YACCO LR ORGANIQUE	



## APPENDIX

---

### MEMO

A series of horizontal dotted lines providing a template for writing a memo.



# INDEX

1. INDEX.....10-2



## A

ABOUT THIS MANUAL .....	1-6
ADJUSTING THE BRAKES .....	5-23
ADJUSTING THE CLUTCH .....	5-23
ADJUSTING THE THROTTLE LEVE .....	5-24
ADJUSTING TOE-IN .....	5-24
ADJUSTMENT METHOD .....	5-23
ADJUSTMENT OF THE LIFT LINK ON THE LOWER LINK ...	3-23
ADJUSTMENT OF THE LIFT ROD (LEFT, RIGHT) .....	3-23
ADJUSTMENT OF THE TOP LINK .....	3-23
AIR CLEANING SYSTEM .....	5-33
AIR CON. SWITCH .....	6-8
ALWAYS USE SAFETY LIGHTS AND DEVICES .....	2-5
ANTI FREEZE .....	5-21
APPENDIX .....	9-1
ASH TRAY .....	6-13
AVOID HIGH-PRESSURE FLUIDS .....	2-6

## B

BATTERY CHARGING .....	5-26
BATTERY DISCONNECT .....	2-8
BATTERY MAINTENANCE .....	5-25
BATTERY MAINTENANCE .....	5-25
BLEEDING THE FUEL SYSTEM .....	5-13

BLOWER CONTROL SWITCH .....	6-7
BRAKE .....	5-5
BRAKE PEDAL .....	3-12

## C

CAB AIR INTAKE FILTER .....	6-12
CAB CEILING .....	6-4
CABIN SYSTEM .....	6-1
CHANGE THE FUEL FILTER CARTRIDGE .....	5-19
CHANGE THE FUEL PRE-FILTER INSERT .....	5-18
CHANGE/VENT FUEL PRE-FILTER .....	5-17
CHANGING ENGINE OIL .....	5-14
CHANGING OIL IN THE FRONT AXLE .....	5-16
CHANGING THE COOLANT .....	5-20
CHANGING THE OILS IN THE TRACTOR .....	5-14
CHANGING THE TRANSMISSION OIL .....	5-15
CHECK AND CLEAN THE AIR CLEANER ACCORDING TO THE FOLLOWING INSTRUCTIONS .....	5-28
CHECK DURING DRIVING .....	4-7
CHECK DURING DRIVING .....	4-8
CHECKING ENGINE COOLANT .....	5-2
CHECKING HOSES AND LINES .....	5-28
CHECKING THE AIR CONDITIONING SYSTEM .....	6-14
CHECKING THE AIR CONDITIONING SYSTEM CHARGE ...	6-14



CHECKING THE BATTERY .....	5-25	DAMAGE OF THE ROPS.....	1-11
CHECKING THE BELT DRIVE.....	5-27	DECALS MOUNTING LOCATION .....	2-22
CHECKING THE WIRING HARNESS AND FUSES .....	5-29	DESCRIPTION .....	1-8
CHECKS AND SERVICE .....	5-2	DESCRIPTION OF TRACTOR CONTROLS.....	3-1
CIGARETTE LIGHTER .....	6-13	DIAGNOSING MALFUNCTIONS .....	6-15
CIRCULATION DIFFUSER .....	6-11	DIFF-LOCK PEDAL.....	3-16
CIRCULATION DIFFUSER .....	6-9	DO'S AND DON'T'S .....	2-20
CLEANING AND CHANGING FILTERS.....	5-17	DO'S-FOR BETTER PERFORMANCE .....	2-20
CLEANING OIL WATER SEPARATOR OF FUEL FILTER ..5-17		DON'TS-FOR SAFE OPERATION .....	2-21
CLEANING THE RADIATOR.....	5-22	DOORS .....	6-3
CLUTCH.....	5-6	DRIVER'S SEAT.....	3-18
CLUTCH & BRAKES.....	5-33	DRIVING THE TRACTOR.....	4-3
CLUTCH DISCONNECTING ARM.....	3-11		
CLUTCH, BRAKE AND HYDRAULIC SYSTEM TROUBLESHOOTING.....	8-6	<b>E</b>	
CONNECTING AND DISCONNECTING IMPLEMENT.....	4-10	ELECTRICAL .....	5-6
COOLANT MANUFACTURER .....	9-10	EMERGENCY EXITS .....	2-9
COOLING SYSTEM.....	5-40	EMPTY WATER TANK .....	5-18
CREEP SHIFT LEVER.....	3-15	ENGINE.....	5-33
CUP HOLDER.....	6-13	ENGINE OIL.....	5-3
CUSHION STRENGTH ADJUSTMENT .....	1-12	ENGINE OIL FILTER.....	5-17
		ENGINE OIL MANUFACTURER .....	9-7
<b>D</b>		ENGINE TROUBLESHOOTING.....	8-2
DAILY OPERATION LOG.....	9-5	ENGINE WARNING LAMP.....	3-4
		EXTERIOR HYDRAULIC LEVER (OPTIONAL).....	3-20



<b>E</b>	
EXTERIOR VIEW .....	1-2
<b>F</b>	
FALLING OBJECT PROTECTIVE STRUCTURE (FOPS) ...	2-13
FILLING DIAGRAM & CAPACITY TABLE .....	5-10
FIXATION POINTS OF LOADER .....	4-11
FOOT OPERATED ACCELERATOR .....	3-12
FOR DAILY OR SHORT TERM STORAGE .....	5-31
FRONT WHEEL DRIVE LEVER .....	3-17
FUEL .....	5-4
FUEL .....	5-12
FUEL .....	5-38
FUEL GAUGE .....	3-4
FUEL SAVING TIPS .....	5-32
FUEL SYSTEM .....	5-38
<b>G</b>	
GAP ADJUSTMENT .....	5-23
GENERAL INFORMATION .....	1-1
GENERAL INFORMATION .....	5-2
GENERAL SAFETY INFORMATION .....	2-22
GREASING THE TRACTOR .....	5-22
<b>H</b>	
HAND THROTTLE (THROTTLE LEVER) .....	3-11
HANDLE FUEL SAFELY AVOID FIRES .....	2-5
HEATING AIR CONDITIONER SYSTEM .....	6-10
HEATING SYSTEM .....	6-9
HEATING SYSTEM CONFIGURATION .....	6-10
HOUR METER .....	3-3
HOW TO CONTROLS CABIN .....	6-5
HYDRAULIC OIL FILTER AND ENGINE OIL FILTER CARTRIDGE .....	5-20
<b>I</b>	
INDEPENDENT PTO .....	3-7
INDEX .....	10-1
INSTRUMENT AND RELATED PARTS .....	6-3
INSTRUMENT AND SWITCHES .....	3-2
INTERIOR DEVICES .....	6-5
INTERIOR LAMP .....	6-7
INTRODUCTION & DESCRIPTION .....	1-7



<b>K</b>		
KEEP RIDERS OFF TRACTOR .....	2-4	
<b>L</b>		
LIGHT SWITCH, INDICATORS AND HORN .....	3-3	
LONG-TERM STORAGE .....	5-31	
LOWERING SPEED CONTROL KNOB FOR THE 3 POINT HITCH .....	3-20	
LUBRICANTS .....	5-11	
LUBRICATING OIL .....	5-34	
LUBRICATING OIL CHANGE INTERVALS .....	5-37	
<b>M</b>		
MAIN FUSES .....	5-30	
MAIN GEAR LEVER .....	3-14	
MAIN SPECIFICATIONS .....	7-4	
MAIN SWITCH .....	3-2	
MAINTENANCE .....	5-1	
MAINTENANCE AND ADJUSTMENT SCHEDULE .....	5-7	
MAJOR FEATURES .....	6-2	
MAJOR SPECIFICATIONS .....	7-2	
MAJOR SPECIFICATIONS .....	7-2	
MOUNTING AND DEMOUNTING IMPLEMENTS .....	2-15	
MOUNTING IMPLEMENT .....	4-11	
<b>N</b>		
NOISE LEVELS .....	7-7	
NOISE LEVELS .....	7-6	
NORMAL BRAKING AND PARKING .....	4-5	
<b>O</b>		
OIL SYSTEM .....	5-34	
OPENING METHOD OF EACH COVER .....	5-12	
OPENING METHOD OF HOOD .....	5-12	
OPERATING THE 3 POINT LINKAGE (TPL) .....	3-22	
OPERATING THE HYDRAULICS .....	3-19	
OPERATION .....	4-1	
OPERATION OF THE DIFF LOCK .....	4-7	
OPERATION THE CONTROLS .....	3-10	
OPERATOR PROTECTIVE STRUCTURE (OPS) .....	2-13	
OTHER MAINTENANCE .....	5-27	
OWNER ASSISTANCE .....	1-9	
<b>P</b>		
PARK TRACTOR SAFELY .....	2-4	
PART REPLACEMENT RECORD .....	9-6	
PARTS .....	1-5	
PERIODICAL CHECK AND SERVICE TABLE .....	5-7	
POSITION OF THE FUSE .....	9-2	





<b>P</b>	
PRACTICE SAFE MAINTENANCE.....	2-6
PRECAUTION TO AVOID TIPPING.....	2-4
PREVENT ACID BURNS.....	2-7
PREVENT BATTERY EXPLOSIONS.....	2-7
PROTECTION CHILDREN.....	2-3
PTO CONTROL SWITCH.....	3-8
PTO GEAR SELECTION LEVER.....	3-18
PTO ON/OFF SWITCH.....	3-7
<b>R</b>	
RADIO, CD PLAYER (IF EQUIPPED).....	6-12
READ SAFETY INSTRUCTION.....	2-2
REAR WINDOW.....	6-3
REARVIEW MIRRORS.....	6-4
RECOGNIZE SAFETY INFORMATION.....	2-2
REMOTE HYDRAULIC CONTROL VALVE COUPLER CONNECTING AND DISCONNECTING.....	3-21
REPLACE V-RIB BELT.....	5-27
REPLACING FUSES.....	5-29
RE-USE AFTER LONG TERM STORAGE.....	5-32
ROLL OVER PROTECTIVE STRUCTURES (ROPS).....	1-10
ROOF HATCH (IF EQUIPPED).....	6-11
ROPS (ROLL OVER PROTECTIVE STRUCTURES).....	1-10
<b>S</b>	
SAFE OPERATION OF YOUR TRACTOR.....	2-14
SAFETY INSTRUCTIONS.....	2-2
SAFETY PRECAUTIONS.....	2-1
SAFETY PRECAUTIONS WHEN USING THE LOADER.....	2-10
SAFETY SIGNS.....	2-22
SAFETY STARTER SWITCH.....	2-9
SAFETY TIPS DURING MAINTENANCE.....	2-14
SEAT BACK RECLINING.....	1-12
SEAT SLIDING.....	1-11
SERVICE.....	1-5
SERVICE PRIOR TO DAILY AND SHORT TERMS STORAGE.....	5-30
SERVICE RECORD.....	9-4
SERVICE TRACTOR SAFELY.....	2-8
SHUTTLE SHIFT LEVER - SC MODEL.....	3-13
SIDE WINDOW.....	6-3
SIGNAL WORDS.....	2-2
SPECIFICATION.....	7-1
SPECIFICATION.....	7-1



SPECIFICATIONS.....	7-2	TRACTOR AN INTRODUCTION .....	1-7
SPECIFICATIONS.....	7-2	TRACTOR HISTORY CARD .....	9-3
STARTING THE ENGINE.....	4-2	TRACTOR IDENTIFICATION.....	1-5
STAY CLEAR OF ROTATING SHAFTS .....	2-5	TRACTOR RUNAWAY .....	2-9
STEERING .....	5-5	TRANSMISSION OIL .....	5-3
STEERING WHEEL AND ELECTRIC INSTRUMENTS		TRAVELING SPEED .....	7-6
TROUBLESHOOTING.....	8-7	TRAVELING SPEED .....	7-5
STOPPING THE ENGINE .....	4-3	TROUBLESHOOTING .....	8-1
STORAGE .....	5-30	TURN BUCKLE STABILIZERS ADJUSTMENT (CHECK LINK).....	3-22
SUB GEAR LEVER (LINEAR SHIFT LEVER).....	3-14		
<b>T</b>		<b>U</b>	
TACHOMETER.....	3-3	UNIVERSAL SYMBOLS.....	2-27
TEMPERATURE CONTROL.....	6-8	UPHILL STARTS ON A STEEP SLOPE .....	4-6
THE PTO MONITOR LAMP .....	3-7	USE OF ROPS AND SEAT BELT.....	2-3
TIGHT TURNS IN THE FIELD.....	4-5	USE OF THE TRACTOR WITH THE ROPS LOWERED CAN CAUSE FATAL INJURIES .....	1-10
TILT LEVER.....	3-18	<b>V</b>	
TIRE PRESSURE.....	5-5	VENT THE FUEL SYSTEM.....	5-18
TIRE SIZE AND INFLATION PRESSURE.....	5-9	VENTILATION .....	6-5
TOWING SAFELY .....	2-12	VIBRATION REFERRED TO THE OPERATOR POSITION... 7-8	
TOWING THE TRACTOR .....	8-8	VIBRATION REFERRED TO THE OPERATOR POSITION... 7-7	
TOWING WITH THE ENGINE OFF .....	8-10		
TOWING WITH THE ENGINE RUNNING.....	8-9		



**W**

WARMING UP .....	4-3
WARNING LIGHTS .....	3-5
WARRANTY .....	11-1
WARRANTY OF THE PRODUCT .....	1-5
WATER TEMPERATURE .....	3-4
WINDSCREEN WASHER TANK .....	6-7
WIPER CONTROL SWITCH .....	6-6
WIRING DIAGRAM OF THE ELECTRIC INSTRUMENT .....	9-2
WORK IN VENTILATED AREA .....	2-8
WORKING LAMP SWITCH .....	6-6
WORKING LAMPS (FRONT AND REAR).....	6-4

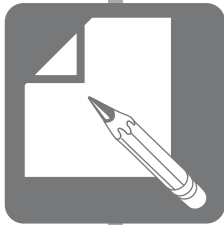

## **WARRANTY**

- 1. ENGINE WARRANTIES.....11-2**
- 2. EMISSION SYSTEM WARRANTY .....11-5**
- 3. RK WARRANTY.....11-13**



# 1. ENGINE WARRANTIES

## ■ ENGINE LIMITED WARRANTY

### What is Covered by this Warranty?

ENGINE warrants to the original retail purchaser that a new ENGINE TNV common rail series industrial engine will be free from defects in material and/or workmanship for the duration of the warranty period.

Note: ENGINE engines may be equipped with external components including, but not limited to: wiring harnesses, electrical devices, control panels, radiators, air filters, fuel filters, and/or exhaust systems that are supplied and/or installed by manufacturers other than ENGINE. For warranty information on such external components, please contact the machine or component manufacturer directly or see your authorized ENGINE dealer or distributor.

This warranty is provided in lieu of all other warranties, express or implied. ENGINE specifically disclaims any implied warranties of merchantability or fitness for a particular purpose, except where such disclaimer is prohibited by law. If such disclaimer is prohibited by law, then implied warranties shall be limited in duration to the life of the express warranty.

### How Long is the Warranty Period?

The ENGINE standard limited warranty period runs for a period of twenty-four (24) months or two-thousand (2000) engine operation hours, whichever occurs first. An extended limited warranty of thirty-six (36) months or three thousand (3000) engine operating hours, whichever occurs first, is provided for these specific parts only: the cylinder block, cylinder head, crankshaft forging, connecting rods, flywheel, flywheel housing, camshaft,



timing gear, and gear case. The warranty period for both the standard limited warranty and the extended limited warranty (by duration or operation hours) begins on the date of delivery to the original retail purchaser and is valid only until the applicable warranted duration has passed or the operation hours are exceeded, whichever comes first.

### **What is not Covered by this Warranty?**

This warranty does not cover parts affected by or damaged by any reason other than defective materials or workmanship, including, but not limited to, accident, misuse, abuse, "Acts of God," neglect, improper installation, improper maintenance, improper storage, the use of unsuitable attachments or parts, the use of contaminated fuels, the use of fuels, oils, lubricants, or fluids other than those recommended in your ENGINE Operation Manual, unauthorized alterations or modifications, ordinary wear and tear, and rust or corrosion. This warranty does not cover the cost of parts and/or labor required to perform normal/scheduled maintenance on your ENGINE engine. This warranty does not cover consumable parts such as, but not limited to, filters, belts, hoses, fuel injector, lubricants and cleaning fluids. This warranty does not cover the cost of shipping the product to or from the warranty repair facility.

### **Warranty Limitations:**

The foregoing is ENGINE's only obligation to you and your exclusive remedy for breach of warranty. Failure to follow the requirements for submitting a claim under this warranty may result in a waiver of all claims for damages and other relief. In no event shall ENGINE or any authorized industrial engine dealer or distributor be liable for incidental, special or consequential damages. Such consequential damages may include, but not be limited to, loss of revenue, loan payments, cost of rental of substitute equipment, insurance coverage, storage, lodging,



## WARRANTY

---

transportation, fuel, mileage, and telephone costs. The limitations in this warranty apply regardless of whether your claims are based on breach of contract, tort (including negligence and strict liability) or any other theory. Any action arising hereunder must be brought within one (1) year after the cause of action accrues or it shall be barred. Some states and countries do not allow certain limitations on warranties or for breach of warranties. This warranty gives you specific legal rights, and you may also have other rights which vary from state to state and country to country. Limitations set forth in this paragraph shall not apply to the extent that they are prohibited by law.

### **Warranty Modifications:**

Except as modified in writing and signed by the parties, this warranty is and shall remain the complete and exclusive agreement between the parties with respect to warranties, superseding all prior agreements, written and oral, and all other communications between the parties relating to warranties. No person or entity is authorized to give any other warranty or to assume any other obligation on behalf of ENGINE, either orally or in writing.

### **Questions:**

If you have any questions or concerns regarding this warranty, please call or write to the nearest authorized ENGINE industrial engine dealer or distributor or other authorized facility.



## 2. EMISSION SYSTEM WARRANTY

### **ENGINE CO., LTD. EMISSION CONTROL SYSTEM WARRANTY- USA ONLY**

#### **Your Warranty Rights and Obligations:**

The California Air Resources Board (CARB), the United States Environmental Protection Agency (EPA) and ENGINE CO., LTD. hereafter referred to as ENGINE, are pleased to explain the emission control system warranty on your industrial compression-ignition engine. In California, model year 2000 or later off-road compression-ignition engines must be designed, built and equipped to meet the State's stringent anti-smog. In all states, 1998 and later non-road compression-ignition engines must be designed, built and equipped to meet the United States EPA emissions standards. ENGINE must warrant the emission control system on your engine for the periods of time listed below provided there has been no abuse, neglect or improper maintenance of your engine.

Your emission control system may include parts such as the fuel injection system, the air induction system, the electronic control system, EGR (Exhaust Gas Recirculation) system and the diesel particulate filter system. Also included may be hoses, belts, connectors and other emission-related assemblies.

Where a warrantable condition exists, ENGINE will repair your off-road compression-ignition engine at no charge to you including diagnosis, parts and labor.





## WARRANTY

### Manufacturer's Warranty Period:

The model year 1998 or later certified and labeled non-road compression-ignition engines are warranted for the periods listed below. If any emission-related part on your engine is found to be defective during the applicable warranty period, the part will be replaced by ENGINE.

If your engine is certified as	And its maximum power is	And its rated speed is	Then its warranty period is
Variable speed or constant speed	$\text{kW} < 19$	Any speed	1,500 hours or two (2) years whichever comes first. In the absence of a device to measure the hours of use, the engine has a warranty period of two (2) years.
Constant speed	$19 \leq \text{kW} < 37$	3,000 rpm or higher	1,500 hours or two (2) years whichever comes first. In the absence of a device to measure the hours of use, the engine has a warranty period of two (2) years.
Constant speed	$19 \leq \text{kW} < 37$	Less than 3,000 rpm	3,000 hours or five (5) years whichever comes first. In the absence of a device to measure the hours of use, the engine has a warranty period of five (5) years.
Variable speed	$19 \leq \text{kW} < 37$	Any speed	3,000 hours or five (5) years whichever comes first. In the absence of a device to measure the hours of use, the engine has a warranty period of five (5) years.
Variable speed or constant speed	$\text{kW} \geq 37$	Any speed	3,000 hours or five (5) years whichever comes first. In the absence of a device to measure the hours of use, the engine has a warranty period of five (5) years.

**Warranty Coverage:**

This warranty is transferable to each subsequent purchaser for the duration of the warranty period. Repair or replacement of any warranted part will be performed at an authorized ENGINE or distributor.

Warranted parts not scheduled for replacement as required maintenance in the owner's manual shall be warranted for the warranty period. Warranted parts scheduled for replacement as required maintenance in the owner's manual are warranted for the period of time prior to the first scheduled replacement. Any warranted parts scheduled for replacement as required maintenance that are repaired or replaced under warranty shall be warranted for the remaining period of time prior to the first scheduled replacement. Any part not scheduled for replacement that is repaired or replaced under warranty shall be warranted for the remaining warranty period.

During the warranty period, ENGINE is liable for damages to other engine components caused by the failure of any warranted part during the warranty period.

Any replacement part which is functionally identical to the original equipment part in all respects may be used in the maintenance or repair of your engine, and shall not reduce ENGINE's warranty obligations.

Add-on or modified parts that are not exempted may not be used. The use of any non-exempted add-on or modified parts shall be grounds for disallowing a warranty.

**Warranted Parts:**

This warranty covers engine components that are a part of the emission control system of the engine as delivered by ENGINE to the original retail purchaser. Such components may include the following:

- (A) Fuel injection system
- (B) Electronic control system
- (C) Cold start enrichment system



## WARRANTY

---

- (D) Intake manifold
- (E) Turbocharger systems
- (F) Exhaust manifold
- (G) EGR system
- (H) Positive crankcase ventilation system
- (I) Hoses, belts, connectors and assemblies associated with emission control systems

Since emissions related parts may vary slightly between models, certain models may not contain all of these parts and other models may contain the functional equivalents.

### **Exclusions:**

Failures other than those arising from defects in material or workmanship are not covered by this warranty.

The warranty does not extend to the following: malfunctions caused by abuse, misuse, improper adjustment, modification, alteration, tampering, disconnection, improper or inadequate maintenance, or use of non-recommended fuels and lubricating oils; accident-caused damage and replacement of expendable items made in connection with scheduled maintenance. ENGINE disclaims any responsibility for incidental or consequential such as loss of time, inconvenience, loss of use of equipment/engine or commercial loss.



### **Owner's Warranty Responsibilities:**

As the off-road compression-ignition engine owner, you are responsible for the performance of the required maintenance listed in your owner's manual. ENGINE recommends that you retain all documentation, including receipts, covering maintenance on your off-road compression-ignition engine, but ENGINE cannot deny warranty solely for the lack of receipts, or for your failure to ensure the performance of all scheduled maintenance.

ENGINE may deny your warranty coverage if your off-road compression-ignition engine or a part has failed due to abuse, neglect, improper maintenance or unapproved modifications.

Your engine is designed to operate on diesel fuel only. Use of any other fuel may result in your engine no longer operating in compliance with GARB and EPA emissions requirements.

You are responsible for initiating the warranty process. You must present your engine to a ENGINE dealer as soon as a problem exists. The warranty repairs should be completed by the dealer as expeditiously as possible. If you have any questions regarding your warranty rights and responsibilities, or would like information on the nearest ENGINE dealer or authorized service center, you should contact ENGINE America Corporation.

Website: [www.ENGINE.com](http://www.ENGINE.com)

E-mail: [CS\\_support@ENGINE.com](mailto:CS_support@ENGINE.com)

Toll free telephone number: 1-800-872-2867, 1-855-416-7091



### ■ EMISSION-RELATED INSTALLATION INSTRUCTIONS (REF)

Failing to follow these instructions when installing a certified engine in a piece of non-road equipment violates Federal Law (40 CFR1068.105(8)), subject to fines or other penalties as described in the clean air act.

### **Installation of Non-road Engines into Equipment**

To ensure engines operate under the certified configurations, ENGINE has established defined application requirements when installing any certified engine into a piece of equipment. The instructions outlined below are included in our certification process and any failure to comply will be considered tampering.

ENGINE certifies engines to operate under variable speed or constant speed conditions. Engines certified as constant speed are prohibited from installation into variable speed applications. The emission control information label will identify an engine certified as constant speed.

### **Allowable Air Intake Restriction and Exhaust Back Pressure**

Resistance to intake airflow and exhaust gas flow is generated in the intake and exhaust systems.

Exceeding the limitations will affect the operation of an engine and its certified configuration. Refer to the installation requirements and limitations of the TNV series Application Manual for the engine being equipped with these systems.



### Allowable Air Intake Restriction

Engine model	Allowable air intake restriction $\leq$ kPa (mmAq)	
	Initial upper limit	Upper limit for air cleaner replacement
All TNV models	2,94 (300)	6,23 (635)

### Allowable Exhaust Back Pressure

Engine model	Allowable air intake restriction $\leq$ kPa (mmAq)	
	Initial upper limit	Upper limit for exhaust system cleaning
All models (3TNV74F)	9,81(1.000)	11,77(1.200)

### In-Use Testing Requirements

Exhaust systems should be designed so that a 20 cm (7,87 in.) extension can be installed to the end of the exhaust pipe for purposes of sampling emissions. For equipment that does not allow installation of an extension pipe, a connection must be designed into the exhaust system for temporary attachment of exhaust sampling equipment. An example of an approved connection would be internally threaded with standard pipe threads of a size not larger than one-half inch, and shall be closed by a pipe-plug when not in use.



### **Emission Control Label**

If you install the engine in a way that makes the engine's emission control information label hard to read during normal engine maintenance, you must place a duplicate label on the equipment, as described in 40 CFR 1068.105.

### **Fuel Inlet Label**

Unless otherwise specified, ENGINE will also provide a supplemental fuel inlet label with each certified engine for installation on the equipment. Permanently attach this label to the equipment near the fuel inlet.

### **Installation Evaluation**

ENGINE CO., LTD. and its regional headquarters will determine approval of applications to the guidelines of the Application Manual, including these Emission-Related Installation Instructions.

To ensure engine performance and exhaust emissions compliance ENGINE will review net rated output based on engine build, intake air restriction, exhaust back pressure, engine heat balance and any other operational characteristic required under the Engine Installation Evaluation process.

### **Engine Maintenance**

Equipment manufacturers are responsible for relaying all emission-related service intervals to the final consumer of the product.

For equipment manufacturers who prepare their own warranty cards, owner's manuals, service manuals, operation manuals and any related documents; they must reference the emission-related service intervals and procedures indicated in Y ANMAR's technical documents: Warranty Statement, Operation Manual, Service Manual and Application Manual.



### 3. RK WARRANTY

#### WARRANTY

All products manufactured and supplied by RK have been designed and manufactured in compliance with all laws and regulations concerning agricultural equipment. If maintained and used in accordance with the inspections, regular maintenance and usage guidelines specified in the user's manual, this product is guaranteed to always safely maintain its optimum state and performance, as well as being guaranteed as follows.

##### **1. Scope of Warranty**

###### **※ (Tractor Non-Rental & Non-Commercial)**

If the agricultural equipment which you purchased is maintained and used normally in accordance with the inspections, regular maintenance and usage guidelines in the user's manual provided by our company, our company shall provide repairs and replacement at our expense for any parts which are revealed by technical analysis during the warranty period below to be defective due to a flaw in the materials or manufacturing.





## ※ (Tractor Rental & Commercial)

If the agricultural equipment which you purchased is maintained and used normally in accordance with the inspections, regular maintenance and usage guidelines in the user's manual provided by our company, our company shall provide repairs and replacement at our expense for any parts which are revealed by technical analysis during the warranty period below to be defective due to a flaw in the materials or manufacturing.

## 2. Warranty Period and Relevant Parts

The warranty period is applied as of the date upon which the agricultural machine was provided to the end user. The warranty period is considered to have ended when either the usage period or usage time expires.

- ① 36 months or 2000 hours of use from the date of purchase for the engine (excluding fuel devices and electronic components) and power transmission devices.  
Power transmission devices refer to the interrupter, transmission, brakes, differential and reduction gear. Engines which have been replaced for free are guaranteed for 12 months.
- ② 24 months or 1500 hours for parts other than those listed in Section ① (not including consumables.) Replaced parts are guaranteed for 3 months or less; they are seen as expiring at the end of the regular warranty period.



## COVERAGE

This Limited warranty is limited to RK repairing or replacing, at RK's option, warranted parts by an authorized RK RK Tractor store at no charge for either the parts or services. Parts replaced under this Limited Warranty are only warranted for the balance of the warranty period.

**1. RK shall have no obligation or liability under this warranty.**

- (1) for normal maintenance or operation services for Products, including but not limited to, providing lubricants, fuel, tune-up inspection or adjustments.
- (2) for any consumable parts when such parts are replaced as a part of normal maintenance or operating services.
- (3) to any exclusions and limitations contained in the Limited Warranty.

**2. Options, accessories, attachments installed by RK Tractor stores which are not manufactured by RK will not be warranted in any way by RK. For information about the warranty or to obtain warranty service on such parts, RK Tractor stores should contact the manufacturer directly**



**3. The Limited Warranty is exclusive and in lieu of all other warranties, whether written, Oral, express or implied, including any warranty of merchantability or fitness for particular purpose.**

**The liability of RK under this warranty is expressly limited to the provisions in the Limited Warranty and in no event shall RK incur any liability (including liability for general, special, incidental or consequential damages, or economic or moral loss, arising out of any failure of the Products) which is not expressly assumed by RK under this warranty.**

**RK**



## 4. PDI CHECKLIST

TRACTOR

Item	Inspection Description	Confirm (v)	Item	Inspection Description	Confirm (v)	
Engine	1. Engine start and stop		Hydraulic Device	1. Hydraulic lifting/lowering operation of implement		
	2. Operation sound (noise)			2. PTO operation		
	3. Amount of Oil and Leakage		Steering system	1. Power steering operation		
	4. Operating throttle lever and pedal		Electronic Device	1. Engaged with Batter terminal		
	5. Operating choke handle			2. Ignition Safety Device		
	6. Air conditioner & fan belt tension			3. Status of Headlight Lighting		
		4. Independent PTO operation				
Transmission	1. Front axle oil level and leakage		Instrument Device	5. Work lamp illumination		
	2. Transmission fluid level and leakage			1. Instrument flash and light		
Driving and Control Device	1. Shuttle shift lever operation			Other	2. Warning alarm and lamp operation	
	2. Each lever operation				1. Status of bolts and nuts in all units	
	3. Front/rear tire inflation pressure				2. Checking oil leakage in all units	
Brake Device	1. Applying parking brake			3. A/C and heater operation		
Warning Decal	1. Status in the attached location		Additional Tools	1. Availability of user's manual, tools, and parts		

It is confirmed that there is nothing wrong with the product before delivery.

Year                      Month                      Day

Inspector:

(Signature)